

FIRE S Improv'd:

Being a
New Method
Of Building

CHIMNEYS,

So as to prevent their

S M O A K I N G :

I N W H I C H

A *Small* FIRE, shall warm a Room better than a much *Larger* made the *Common Way*. With the manner of altering such CHIMNEYS as are already Built, so that they shall perform the same Effects.

Illustrated with Cuts.

Written in *French*, by Monsieur GAUGER:
Made *English* and Improved,
By J. T. DESAGULIERS, M. A. F. R. S.

By whom is added,

The manner of making COAL-FIRES, as useful this *New-Way*, as the WOOD-FIRES propos'd by the *French* Author, Explain'd by an Additional Plate. The whole being suited to the Capacity of the meanest Work-man. 5/1.140

L O N D O N,

Printed for J. SENEX, at the *Globe* in *Salisbury Court*, and E. CURLL, at the *Dial* and *Bible* against *St. Dunstan's Church* in *Fleet-Street*, 1715.

Price 3 s.

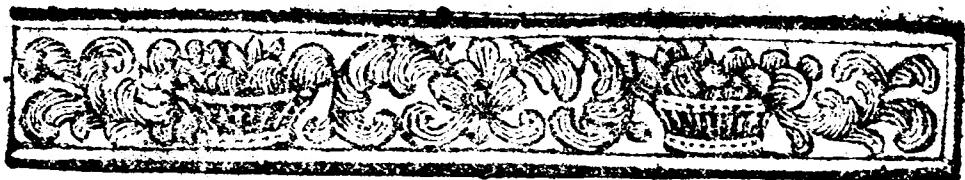

To the Right Honourable HUGH,
Earl of CHOLMONDELEY, Vis-
count MALPAS, Baron WICH
MALBANK, Viscount KELLY in
the Kingdom of *Ireland*; Treasurer
of his MAJESTY'S Household.

My LORD,

I Have presum'd to dedicate this
small Treatise to you, not with a
Design to publish your Merit, which
would be needless; but because it
gives me an Opportunity of returning
my most unfeign'd Thanks for those Fa-
vours you have been pleas'd to confer
upon me.

I am bound in Gratitude to offer
you this small Tribute of Acknow-
ledgment, and inclin'd by Interest to
desire your Lordship's Patronage and
Protection of it; for I am persuaded
that

THE DEDICATION.

that it cannot be better recommended to the World, than by your Approbation of it.

Did you confine your self to Classical Learning, of which no Body is a better Judge than your Lordship, I should have declin'd the presenting you with a Work of this nature: Neither should I think that what can be said on this subject would be worthy the perusal of so good a Philosopher; were I not well assured that your Lordship has a greater value for the most simple Things, if practical and useful, than the finest Speculations on Matters of meer Curiosity.

Had I given but a bare Translation of the French Author, yet I shou'd have hop'd for its Acceptance from such an Encourager of Physical and Mathematical Sciences; but now that I have improv'd the Hint so far as to make it of general Use in England, I shall more boldly offer you the little which I contribute, in my way, to the Good of the Nation,

The DEDICATION.

*Nation, which your Lordship is ever
studying to promote in the highest Con-
cerns. I am,*

My LORD,

YOUR LORDSHIP'S

Most Humble

and Obedient Servant,

J. T. DESAGULIERS.

To

To the R E A D E R.

Such a Demand has been made for this Book since it was first Advertiz'd, that some Mistakes have been committed thro' hast; we must therefore beg of the Reader to correct the following,

E R R A T A.

PAge 5. line 8. read confirm'd. p. 7. l. 7. r. every way. p. 8. l. 3. r. must move in a line. p. 11. l. 5. r. reflect Heat, p. 16. l. 4. r. causing it. p. 18. l. 4 & 5. r. under the Mantle-Tree. p. 19. l. 15. dele that. p. 21. l. 25. r. Wax-Candle. p. 22. l. 14. r. specifically lighter. p. 23. l. 4. r. successively. l. 19. r. into. p. 24. l. 21. r. under the Mantle-Tree. p. 29. l. 19. r. Cubic Feet. p. 40. l. 1. r. temperate. p. 41. l. 9. r. than. p. 48. l. 8. r. Bodies. p. 61. l. 6. r. behind the Mantle-Tree. p. 63. l. 1. r. Funnel drawn on their Wing on one side. l. 18. r. under the Mantle-Tree. l. 22 & 23. r. whose Wings are bent. p. 65. l. 19. r. the Wing. l. 21 & 22. r. the Plaue under the Mantle-Tree produc'd. p. 66. l. 3. r. the Wing. l. 17. r. the falling Wing of the Funnel. p. 77. l. 8. r. narrower at top. p. 88. l. 19. r. the Wings of it Be H. p. 89. l. 1 & 2. dele so that it may be equally distant from B and H. and r. and from a Point. p. 95. l. 26. r. of Book I. p. 98. l. 4. r. must be. p. 109. l. 3. r. joyn. p. 111. l. 6. r. in at Dy. p. 119. l. 1. r. p'd. p. 123. l. 6 & 7. r. Wheel and Pinion. p. 125. l. 27. r. make use of Tin. p. 129. l. 24. r. we have said. p. 130. the last line, dele down. p. 139. l. 29. dele not. p. 157. l. 2. r. upper part. p. 158. l. 21. r. fig. 10.

A D V E R-

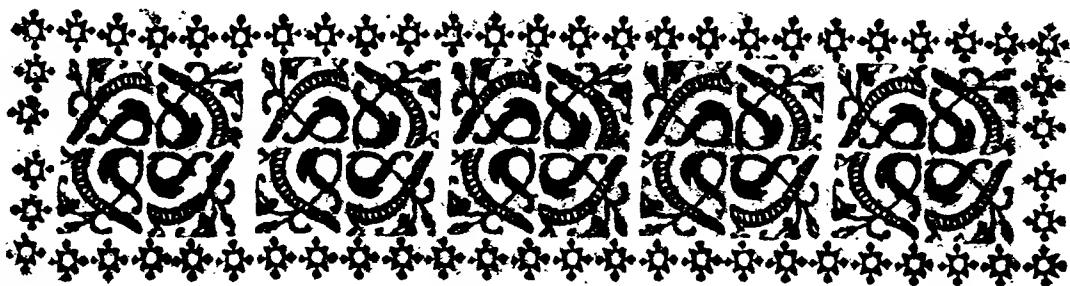

A D V E R T I S E M E N T.

THE best Workmen that I know for curing the smoaking Chimneys, and performing what is directed in this Book, most effectually, and at the most reasonable Rates, are *Henry Hathwel*, Bricklayer; living over against the *George Inn* in *Hedge-Lane*, near *Leicester-fields*; and *William Uream*, who may also be heard of there: Having try'd them several times with good Success.



T H E

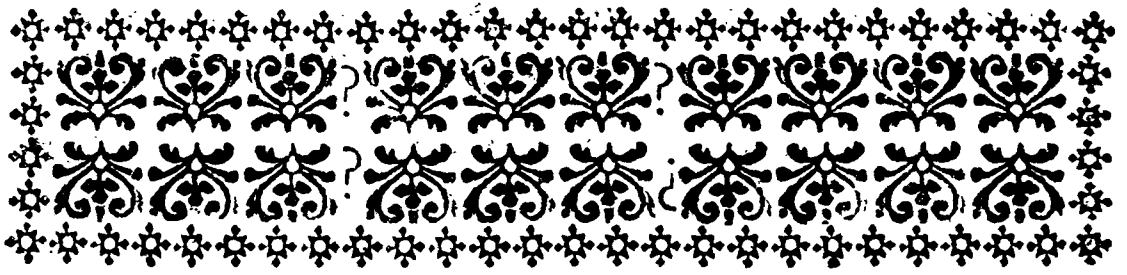

THE
TRANSLATOR'S
PREFACE.

THE usefulness of this Book has induced me to give it the World in English. The Matter contain'd in it will be diverting to every Gentleman; and the manner of reducing it to Practice, easily comprehended by the meanest Work-man. I have omitted whatever I thought Superfluous in the Author, to make way for some Observations of my own, upon this Subject; that nothing might be wanting to make it of general Use.

A 2 Use.

The Translator's Preface.

Use. He has considered only the Improvement of Wood-Fires, but I have shewn how Turf or Coal may be burnt in these Chimneys, with all the Advantages that he proposes from his new Construction.

The Author in his Preface shews, that Contrivances are not the less valuable, for being simple; however some People may admire those only that are the Effect of a great deal of Study, and make a Show with a very complex Apparatus. What he proposes to do by his Method, is, to light a Fire with the greatest Ease, and if you will, make it flame all the time without the trouble of Blowing; to make a Room very warm with a little Fire, which may also give heat to another Room; to disperse the Heat so uniformly as to take away the usual Inconveniences of being obliged to creep near, or too sit at such a Distance from the Fire, that we are either roasted before or starved behind; to make us breath fresh Air constantly, which shall be of any degree of heat that

you

The Translator's Preface

you wou'd have it, without ever being troubled with Smoak or Moisture in any part of the Room; to shew how to extinguish by ones self, and in a Moment, any Fire that should happen in such Chimneys.

Long Experience in his use of the new Chimney, has confirm'd the fore-mention'd Particulars; and what is remarkable, is, that in the severe Winter in 1709, when Water wou'd freeze by the Fire-side almost every where else, it was not at all frozen in his Closet, tho' expos'd there all Night, and the Fire continued no longer than till Midnight.

The Treatise is divided into three Books, the First shews the Inconveniences of the common, and the Conveniences of the new Chimneys.

The Second Book gives the Reasons why the new Chimneys cannot possibly Smoak.

And the Third, which is purely Practical, informs the Work-Man in such

The Translator's Preface.

*an easy manner, that they may without
any further Directions perform what is
requir'd ; in a more or less simple manner,
as any Gentleman shall think fit.*

*Westminster,
May 3. 1715.*

J. T. Desaguliers.



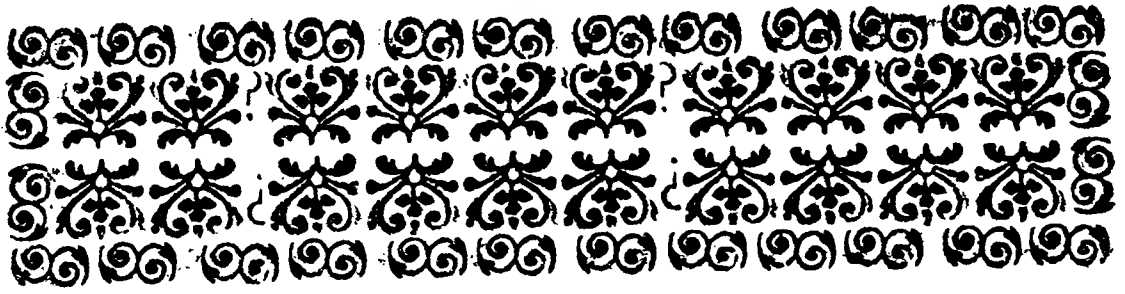

F I R E S Improv'd, &c.

C H A P. I.

Concerning Fire, its Rays of Heat, and the way that we are warm'd by it.



luminous Bodies throw out Rays of Light every way round, so does Fire dart out every Rays of Heat; for whatever way we come near the Fire, we may be sensible of their Impulse, which gives us a Sensation of Pain when we come too near.

By the Rays of Heat, are meant, the Particles of the Fuel which are darted from the Fire; and are propagated round about either directly, that is when they come immediately from the Fire, or by Reflection when they are beaten back from Bodies, against which they strike; and as they are reflected they follow the same Laws as the Rays of Light, having their Angle of Incidence equal to that of Reflection.

All Rays of Fire except those that go straight upwards, whether direct or reflected, ^{love} must ~~be~~ ⁱⁿ a Line which it is perhaps impossible and wholly needless to describe: For, as well the Rays that are darted in an horizontal, as those that are sent out in an inclin'd Direction, must also have a tendency perpendicularly upwards; because Experience shews us, that all little Bodies heated, endeavour to go upwards: Thus in Water or Air, the warmest Particles go towards the upper Parts, and still rise as they are heated. A Ray of Heat then goes on by a compound Motion made up of its Impulse, according to the direction which it receives from the Fire, and its constant tendency upwards, so that the farther a hot Particle is gone from the Fire, the higher it has ascended.

The Use of this Consideration will appear in the following Pages.

Fire may give Heat to a Room, and the People in it.

1st. By its direct Rays.

2^{dly}. By its reflected Rays.

3^{dly}. By a kind of *Transpiration*, that is, when its Heat is transmitted thro' a solid Body, as in the Case of Stoves.

By the Heat of the Fire, is meant, that Motion of its Parts, which causes in us that Sensation which is call'd Heat; and sometimes Pain when it is too violent.

In common Chimneys the Fire gives no Heat by *Transpiration*; sends forth but few direct Rays, and fewer reflected ones, as will appear in the next Chapter; but in the Chimneys described in this Treatise, the Fire sends out more Rays into the Room, and warms much more by *Transpiration*, than by its direct or reflected Rays.



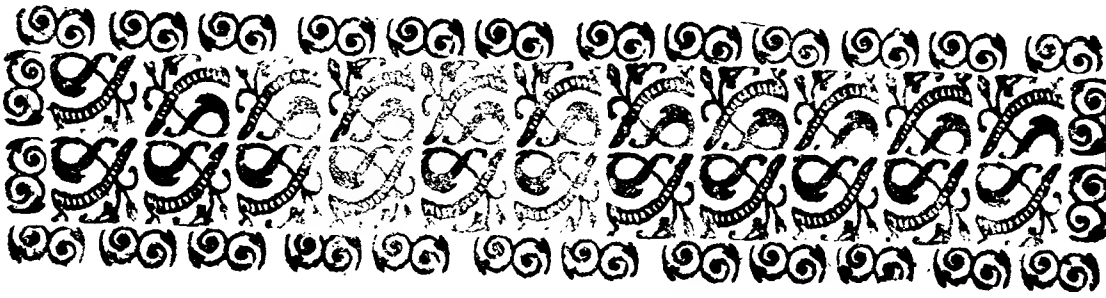

C H A P. II.

The common way of Building Chimneys with the Jams parallel, and the Breast inclin'd, is not proper for reflecting Heat into a Room.

[Fig. 1.] **S**upposing the Fire Ff in a common Chimney $ABba$, whose Sides or Jams AB , ab , are parallel to each other, the Ray of Heat fG , will be reflected to M ; the Ray fH upon it self into f ; the Ray fl into N ; and the Ray fL into P ; and as the Ray fL going from f to L , constantly rises, as it does also when after Reflection it goes from L to P , [Fig. 3] it must get within the Flue before it reaches P , and then wherever it strikes against oR , the fore part of the Funnel which is inclin'd to the Horizon, it will be reflected upwards into the Chimney, always supposing the Angle of Incidence equal to that of Reflection, and therefore it cannot go into the Room.

[Fig. 1.] Thus if we examin all the Rays that fall between H and a , we shall find that none can be reflected into the Room except those that fall upon the extremity of the Jam towards a ; but as they have lost most of their

their

neir strength before they can get thither, upon account of their distance from the Fire, they are but very weakly reflected, and therefore give but little Heat; besides Jams of Plaster are very unfit to reflect Light, by reason of their softness and porosity.

The Ray fH being reflected upon it self to f , cannot enter into the Room.

The Ray FG which is reflected to M , whatever reflections it undergoes afterwards, must necessarily go up into the Chimney, and can go out no other way than at top of the Funnel, the same will happen to all those that are reflected betwen H and Bb ; as also to all the Rays which fall from F upon AB ; and from this we may judge of the Effect of those which going from any part of the Fire fall upon the Jams AB , *ab*.

[Fig. 3.] All the other Rays as FAB , which going from the Fire F , strike against the Back, if they have ascended ever so little above the Level of that part of the Fire, from whence they came before they hit the Back, make a very small Angle with it; and therefore after Reflection go up the Chimney, or if any of them, as $FGMN$, strike against the Breast oR , a second reflection throws them within the Chimney, where they rise and are lost: Therefore scarce any but direct Rays which come from the fore part of the Fire can come into the Room to warm it, and even those must come forward in an horizontal or nearly horizontal

rizontal Direction; for such as are ever so little inclin'd, rising as they go from the Fire, are almost all got into the Funnel before they have reach'd the under part of the Chimney-Piece as FI, and striking upon the Breast o R, which is inclin'd, they are also reflected into the Chimney, and become uselefs; as for the Rays that go upright, nothing can hinder them from getting out at top of the Chimney.

Therefore the common way of building the Breast and Jams of the Chimney lets so few Rays of heat come into a Room, as to make the Fire of very little Use.

Of late, indeed, Builders have rounded the corners of Chimneys, cover'd the Jams or Sides with Plate Iron or Brass, streighten'd the Breast to make Flats under the Chimney Piece, carried the Flue or Funnel bending, and by that means have given more Heat to the Rooms; but the Method mention'd in the next Chapter will out-do all that.



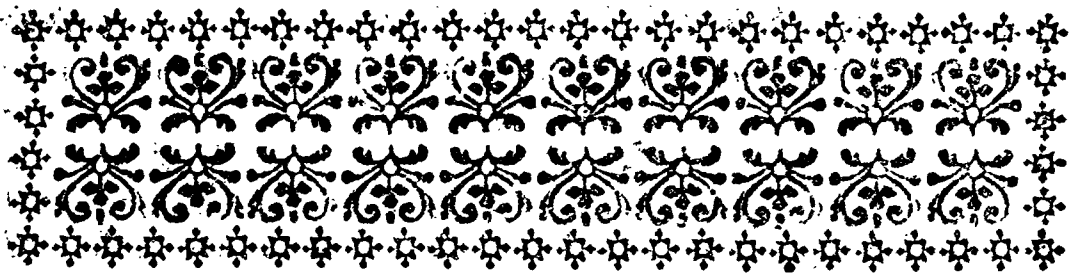

C H A P. III.

Parabolical Jams, and an Horizontal Plane under the Chimney-Piece, are the fittest for reflecting Heat into a Room.

GEOMETRY teaches that all Rays which coming from the Focus of a *Parabola*, strike upon its sides, after Reflexion go on parallel to the Axis.

[*Fig. 2.*] If therefore on the back part of the Hearth of the Chimney *ABba*, you take the Length *Cc* equal to the Length of the Wood that you wou'd burn, as for example of 22 Inches; and from the Points *Cc* you draw the Perpendiculars *CD, cd*, for the Axis of two half *Parabolas's* whose *Vertex's* are *Cc*, and *Aa* the distance of the Breadth of the Chimney be two Points of the said *Parabola's*; then if those Parabolic Jams, *A.C, ac*, be cover'd with Plate Iron, Brass, or Copper, and *oim* [*Fig. 3.*] the under part of the Chimney Piece be made parallel to the Horizon, and as broad as may be, lea-

B

ving

ving only 10 or 12 Inches for the passage into the Funnel; I say, this Chimney will not only reflect a great deal more Heat than common Chimneys, but as much as any Chimney can possibly do.

[*Fig. 2.*] For if Ff be the two Focus's of the half Parabola's, when the Billets whose Length we also suppose Ff , are on fire, the Rays of Heat darted from the said Focus's Ff , which in common Chimneys cannot go into the Room, and so are useless, will here be reflected parallel to the Axis cd , to m, ϕ, n, p , and consequently go into the Room; and those which ascend forwards at 12, 15, or 20 Inches from the Back, and in the common Chimneys wou'd upon account of the Inclination of the Breast oR , [*Fig. 3.*] be reflected inwards, will here strike against the Plane oim which is parallel to the Horizon and therefore be reflected into the Room: So will the Rays FGm if their first Angle of Reflexion be sensible, and by that means come into the Room towards n ; and much more the Rays Fit which come directly, and therefore with a greater force from F .

Moreover, tho' the Chimney be as wide as in the first figure, the *Jams* are much nearer to the Fire, and therefore will reflect more Heat and more strongly; than the Plain

Plain *m i o* not only throws back into the Room, the direct Rays as *Fil*; but also those that are reflected from the Back as *FG mn*.

[*Fig. 2.*] If we examine the Rays which come from any part of the Fire between the *Focus's* of the *Parabolas*, tho' they are not reflected from the *Jams* in such manner as to go on parallel to the Axis *CD, cd*, yet they will all be reflected obliquely into the Room, as *F H I*.

[*Fig. 3.*] Some may imagine that the Plain *m i o* being horizontal and going so near the Back, may cause the Chimney to Smoke; but we shall hereafter shew that the Effect will be quite contrary.

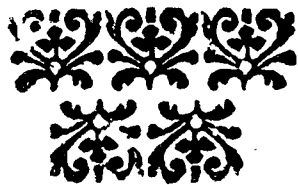

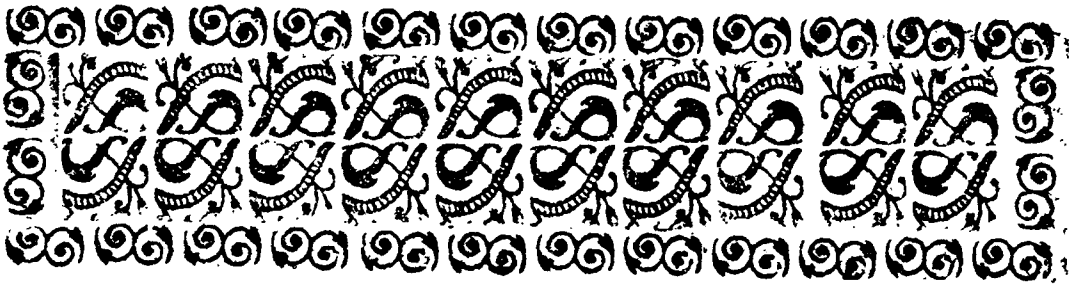

C H A P. IV.

Of the Vent-Hole or Bellows; the reason of its blowing, and the manner of its encreasing the Heat, and causing it to be reflected.

[Fig. 2. 3.] **I**n the middle of the Hearth, at about 10 or 12 Inches distance from the bottom Plate, must be made a Trap-Door Z that may easily open and shut, and under it a little hollow Passage communicating with the outward Air; when this Trap-Door is lifted up a little way, the Air from without will go out thro' the Passage X of the Bellows or Vent-Hole; for there will always be a greater Pressure of Air from without, than from within the Room, whether the Wind blows, or the Weather be calm; if there be a Fire in the Hearth, because the Heat of the Fire rarifying the Air, and driving part of it up the Chimney with the Smoak, there will be a kind of *Vacuum*, or at least, the Air will be made so thin over the Vent-Hole, as to press less than that which

which is coming from without; the external Air therefore will rush in violently, and not only light the Fire, but cause it to flame even tho' the Wood should be green, and also forcibly drive the Flame and Rays of Heat as *FG mn*, *FST* so as to make them beat back into the Room after one or two Reflections, when the Fire is lighted.

The use of the Vent-Hole is not only to light the Fire, and cause it to flame, but it has several other advantages, as will appear in our second part. Neither is the Invention of it new; for I my self us'd it five and twenty Years ago, having seen the use of it in other places; but then it served only to light the Fire.

C H A P. V.

IN this Chapter the Author only shews the way to describe the Parabolical Jams of the Chimney, and give the demonstration of his Method, but it is so easy to perform this, that we shall pass it over; especially, since he refers us to an easy way of drawing them nearly parabolical, which you will find in the Third Book; and in practice it will do as well as if they were truly

parabolical, as they consist of a streight Line and an Arc of a Circle.

This way of making the Jams nearly parabolical as in *Fig. 2.* and the Plane under the Chimney Piece Horizontal as *oim Fig. 3.* will be of little Cost, and great Advantage to Chimneys already built; especially if the Vent-Hole be added; but those that will add the Contrivance behind the Back of the Chimney, will reap several other advantages from it, which will be shewn in the second Part of this Book.



PART.

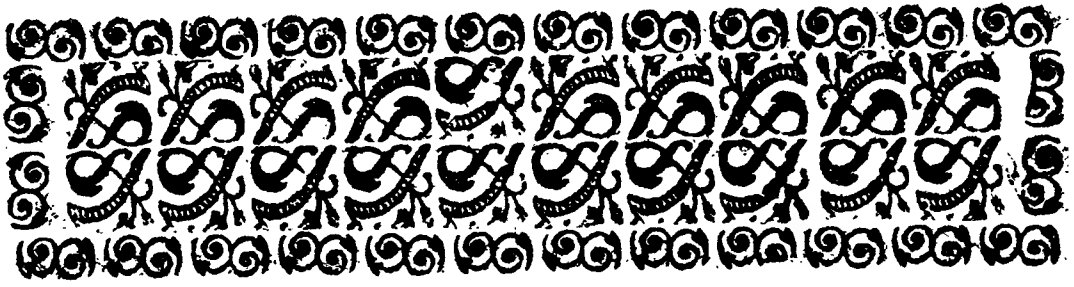

PART. II.

BOOK. I.

CHAP. I.

*Concerning the sudden Heat given to the Air;
and how the warmest Air gets above that
which is cold.*

An Account of an Experiment or two, made
to this Purpose, will best prove what I
affirm.

EXPERIM. I.

I Took a Tube of Iron of 3 or 4 Inches
bore bended in the manner of a Syphon,
and fitting the longest Leg of it so into the
Wall, that the North Wind from without
came into it freely, the Air that ~~that~~ came
into the Room thro' the hole of the short
Leg, was cold enough to freeze Water; but
when

when I laid the said short Leg upon the Fire, the Air rush'd in thro' the Tube with the same violence as before, and rather swifter, and very hot, tho' the heated part of the Tube was but about a Foot long.

Now a Chimney cannot warm Air after this manner, and yet appear handsome; because tho' we suppose the Back and Jams of it hollow behind, and Plate Iron or Brass between the Fire and the Cavity; yet Air passing thus behind, cannot be so heated as if there was a Fire round it, as in the case of the Tube: But Hollows may be so contriv'd, as to warm a Room in a little Time, how cold soever the Weather is, which is all that is requir'd here.

Another Property of the Air, is, that the warmest Air always gets above the cold. To be certain of it, and know the difference of Heat, at top and at bottom of a Room, I made the two following Experiments:

EXPERIM. II.

I hung up two *Air-Thermometers* in my Room, the one at top near the Ceiling, and the other at bottom, near the Floor, and the Liquor ascended much higher in the upper than in the lower *Thermometer*, tho' it was farther from the Fire than the other: then

then changing the places of my *Thermometers*, the Liquor in the upper still wou'd rise, whilst that in the lower descended. This succeeded all the several times that I try'd it; and when I took the upper *Thermometer* down to the middle way betwixt the top and bottom of the Room, and took up the lower *Thermometer*, to see close to it, the Liquor subsided in that which had been the upper *Thermometer*, and rose in that which had been the lowest; which shews, that in a Room where there is a Fire, the lowest part of it is the coldest place, and the higher you go, the warmer is the Air; whence may also be concluded, that the lower the Ceiling of a Room is, the better it is for warming ones self in Winter.

EXPERIM. III.

Take a Gun Barrel, or any other Iron Tube open at both Ends, and laying the middle of it horizontally upon the Fire, you will feel a little Heat coming out at each end; but if you lay it assaunt, the Air will rush out with force enough to blow out a small Wax Candle at the upper end of the Tube; which will be warm from the Fire to the upper end, whilst the other part of the Tube from the Fire downwards will remain cold.

cold: Then if you change ends, still the Air will rush out at the upper end, which will be warm, and the lower end will become cold, even tho' it should be the shorter end; nay, tho' you shou'd stop the lower end close, yet you wou'd feel some warm Air come out at the upper end, tho' not with so great Velócity as before.

If such a Tube be bent, the Experiment will be much more sensible; * and indeed any one that considers how Heat affects the Air, will be convinc'd that the thing must necessarily be so; for the heated Air being rarify'd, becomes specifically ~~lighter~~ than the cold Air, and so must get up above the cold.

* *Whilst an Oven is beating, and the Flame rushing out; any Body may put in their whole Arm near the lower part of the Oven, without feeling any very great Heat, tho' it be quite otherwise as soon as the Fire is put out.*

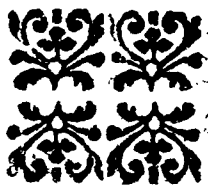

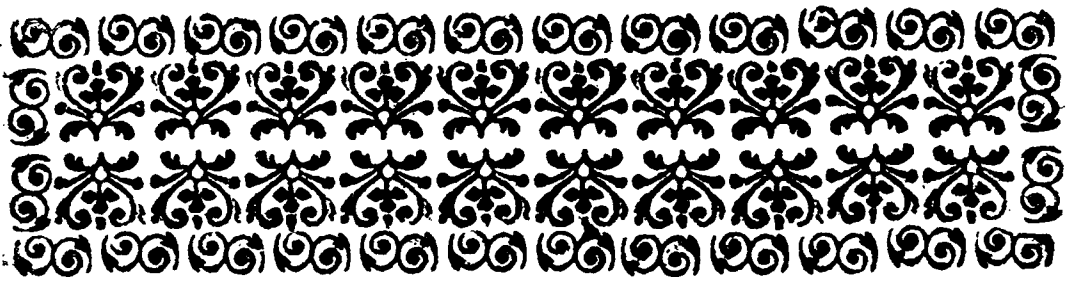

C H A P. II.

The inner Fabric of the inside of the Chimneys; how the Air goes into the Hollows, is warm'd, and then seccessively warms the whole Air of the Room; how the Air of another Room may be warm'd there, and other advantages of this Contrivance. [Fig. 6.]

WE suppose the whole Compass A H C, *cha* of the inside of the Chimney coverd with a Plate of Iron, Brass, or Copper; and behind it a void space about four Inches deep, divided by several Partitions, which form several Cavities, Cells or square Tubes, the first communicating with the second, and the second with the third, and so on; making altogether as it were a sort of a recurved Canal, one of whose ends D must be at bottom, and the other at top of one of the Jams coming out iuto the Room; so that the Air can go in at the lower end D, and go out at the upper end of it R.

We may also suppose the under part of the Hearth hollow, and cover'd with Plate
Iron

Iron; nay, and the under part of the Chimney Piece likewise hollow, like a Pipe; so, that all the Cavities behind the Back, Jams, under the Hearth and Chimney Piece altogether make the foremention'd winding Passage.

We shall in the third Book determine the different Bigness, Contrivance, and Situation of those Cavities, and how to fit them to larger or smaller Rooms; but their Effects we shall shew in the following Chapters; we are only now to take it for granted, that the Fire made in the Hearth, can warm some one of the Surfaces, of each of those communicating Cavities.

Now supposing this Passage for the Air behind the Chimney; as soon as a Fire is made, it will warm the whole compass of the Chimney, the hollow under the Hearth and the bottom and backside of the Passage under the Chimney Piece (if there is one,) and consequently the Air within the Hollows that those Surfaces shut up, and the cold Air, which will come at the lower Entrance D, will begin to grow warm in the first Cavity; then as it comes thro' the second, its Heat will increase, still it will grow hotter in passing thro' the third, &c. so that it will come out very warm, thro' the upper hole R or r.

As

As long as there is any Fire in the Room, there will by this means be a constant Circulation of the Air, thro' those warm'd Hollows, because the Air in them being rari- fy'd, will be succeeded by the more dense, and therefore stronger Air which comes in at the bottom D, and having receiv'd a great degree of Warmth in going thro' all the Hollows, it goes out at R, and gets to the upper part of the Room, the cold Air all the while coming down and succeeding at D till the whole Air in the Room has pass'd thro'; which it may do, till it has acquir'd what degree of warmth you please.

The advantage of those Cavities, consists in the long journey of the Air through them; for if there was only one great Hollow, the Air cou'd not have time to receive a sufficient degree of Heat, especially if it came in from without Doors.

Not only the Air of the Room, in which the Fire is, may be warm'd by such a Circulation; but if you bring in the Air from another Room (in which there is no Fire,) thro' such a Channel, so that it may come from the lower part of it, and go into the Hole D, a large Pipe also going from R to the upper Part of the said Room, after a few Circulations, it will be sufficiently warm'd: Which will be of no small Advantage in several Cases.

C

This

This way of warming a Room, gives heat to all the People in it, tho' at a distance from the Fire ; keeps every place dry, still leaving the Moisture that it had, or gets in circulating thro' the Room, in the Cavities behind the Fire : So that no moisture, even in the greatest Thaws, can damage the Goods in such a Room.

When the Air of the Room is sufficiently warm'd, you may hinder it from receiving any greater degree of Heat, without putting out or diminishing the Fire, if you shut up the Hole R, where the warm Air comes in.

If you shou'd only shut up the lower Orifice D, warm Air would still continue to go out at top, but in a smaller quantity, as we shew'd in the foregoing Chapter, that it wou'd go out at top of the Iron Tube, tho' it was stopp'd at bottom ; because as the warm Air went up, cold Air would go in its Room to the bottom, and so a constant Circulation of it wou'd be made there.

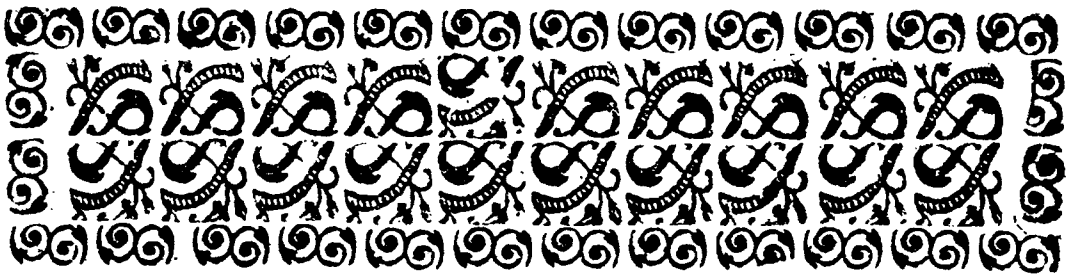

C H A P. III.

After what manner the abovemention'd Cavities, may be made use of, for warming a Room, by letting in the external Air through them, tho' the Air be never so cold; the way that such Air goes into the Room, how it warms it, and the manner of knowing in what time it will be sufficiently warm'd, how it may serve to encrease or diminish the warmth, without encreasing or diminishing the Fire. [Fig. 6.]

IF the outward Air be brought into the Cavities behind the Chimney, by carrying on a Communication from the Hole D, quite out of the House, the Room may also be warm'd, and sooner, as well as to better purpose, than when we only cause the Air in the Room to circulate, for in the first Case, the Air that goes out of the Hollows after it has acquir'd a degree of warmth in passing thro' them, warms the cold Air of the Room, only by mixing with it, and communicating some of its Heat to it; and

as the warm Air that goes out every moment is but in a small quantity, in comparison to that which fills the whole Room, a considerable time must be taken up, before all the Air in the Room is sensibly warm'd, especially when the Weather is very cold, and the Chamber is very large; for that Air does not go thro' very fast: But it is quite otherwise when we make Use of the External Air; for besides that a great quantity will then go out in the same time, thro' the Hole R or *r*, because it goes quicker, as it is always more press'd from without, than from within the Chamber (as we have already hinted.) This is not only done by this warm'd Air, bringing its Heat into the Room, and warming the People in it; but by its driving out the cold Air, and succeeding instead of it. And that is perform'd in the following manner.

The warmest Air always rises above that which is colder, and therefore the outward Air, which comes into the Chamber, after it has pass'd thro' the Cavities of the Chimney when there is a Fire, becoming warmer than the rest of the Air in the Room, gets above it quite to the Cieling, and so much room as it takes up, so much of the cold Air below is driven up the Chimney, as being the only way that it has to get out at;
and

and therefore after the Fire has been lighted some time, all the Air that was in the Room, before the Fire was made, has been driven away up the Chimney, by the Push of the External Air, which comes in warm'd. Now since in time all the cold Air will be gone out of the Room, it may be requir'd to know in how long time that will happen; which may be found after the following manner.

[Fig. 6.] If a piece of Paper P hangs from the Cieling by a Thread, over against the Hole r , thro' which the warm Air comes into the Room, that Air will drive the Paper before it as it comes into the Room: now if the Paper be driven two foot in the fourth part of a second, the Hole being six Inches square, then will more than two square feet of Air come into the Room, *cubi* in one second; for as the Air spreads every way, as it comes out of the Hole r , it will push with less force against the Paper, the farther the Paper is from the Hole; thus if more than two square Feet of Air, come into the Room in one second, about 125 square feet will go in during the space of a Minute, if the Velocity with which the Air rushes in, be such as we suppose it; but it is always greater if the Wind blows ever so little.

Now if we suppose the contents of the Room, to be 2000 square feet; then in 15 Minutes, or a quarter of an Hour, as much Air as it can contain, will have enter'd into it; and two or three times more if its Velocity, or the Hole r be greater than we at first suppos'd.

Nevertheless, we must not conclude that all the cold Air which was in the Room, is absolutely gone out of it; for some of the hot will mix with the cold that goes out up the Chimney, but we are at least certain, that the greatest part of the cold Air is gone out, and therefore that the whole Air will in a quarter of an Hour be very much chang'd, and well warm'd, and that in half an Hour it will be wholly chang'd. Not that the Air which remains in the Room after that time, is as hot as the Air which comes into it from the Hollows, because as this Air comes out, and goes up towards the Cieling, it passes thro' Air colder than it self, and therefore as it warms it, it must lose of its own Heat; but then as the Room grows warmer, this entering Air loses less and less of its Heat every Moment, because as well the Cavities as the Air in the Room, are more and more warm'd; and therefore in a quarter of an Hour, or half an Hour's time, the
Heat

Heat will be sufficient to warm every Body in the Room.

Air coming this way into a Room, not only drives out the cold Air, but hinders it from coming in under Doors, or thro' Casements which don't shut close, or at least, from coming in so fast as usually; for the Room being always full, the External Air meets with more resistance, and that little which may come in, enters with less force, and mixing it self with the warm Air as it comes in, is heated before it can reach the People in the Room; and therefore, can no way be troublesome to them, unless they are too near the Doors or Windows. Nay every crack or passage in a Door or Window, and every little cranny may be stopp'd up close without fear of the Room smoaking; whereas, when Chimneys are built the common way, sometimes the External Air must be let in at the Door or Window to keep the Chimney from Smoaking.

[*Fig. 6.*] There is indeed an Inconvenience, which is, that warm Air entering continually, will at last make the Room too hot; but this is easily remedied by stopping up the Hole *r*, where the hot Air comes in; but then as there would no longer be a Circulation of fresh Air, it is better to have a direct Communication with the External
Air

near R or *r*, the place where it comes out after it is heated in the Hollows. Thus you may sometimes have hot and sometimes cold, and sometimes temperate Air, in what proportion you please, by opening sometimes one Hole, sometimes the other, and sometimes both. We shall in the third Book give the Method of doing this conveniently.

If any one wou'd have the warm Air that comes into the Room, to fall with all it's Heat on their Hands or Feet, to warm them in a little time, and keep them warm at any distance from the Fire, they may easily do it by setting one end of a Tin or Pastboard Pipe, at the Hole R or *r* where the warm Air comes in, and the other end near the Part which they wou'd warm: Such a Pipe may be carried into a Bed and warm it to any degree, by discharging its heated Air into it; and as such a Tube takes up but little room, the Bed may be warm'd whilst any Body is in it, and the warm Air may be thrown upon any Part of the Body, so as to warm it as long as you please, which will be of great Use, especially in some Distempers, where it is requir'd to apply warm Napkins constantly to a Patient; those that can get no Heat in Bed in hard Winters, may be thus warm'd.

The

The Circulation of the Air of the Room might serve for those uses, but very weakly, for Reasons before shewn; neither will it be so proper as this way, for keeping the Goods in the Room from Moisture.

C H A P. IV.

To shew that when a Room is warm'd by Air which is constantly new, it will defend us against several Inconveniencies, and especially the Ladies; that it is of great Advantage to sick People, and those which visit them.

TO be soon and agreeably warm'd by External Air brought into a Room after the above mention'd manner, is not the only or the greatest advantage reap'd by our new Invention; for as well the Inconveniencies of a great Fire, as that of extreme cold are remov'd. The larger Particles of the Fuel darted out against us, when we have too large a Fire, or when we are too near the Chimney, burn and dry up the Lungs, and ruin the Eyes, as may be perceiv'd by their Pain and Redness; spoil the delicate Skin of the Ladies, hurt the Eye-Lids, and destroy the finest Complexions; all

all which Evils are prevented by the use of the new Chimneys.

As for sick People, they may be look'd upon as absolutely necessary; for the corrupted Breath of Patients, the ill Humours which go out of their Bodies by Transpiration, Particles from their Physick, and their Excrements mixing with the Air that continues always the same, (because we dare not in cold Weather open any place to let in fresh Air) vitiate the Air more and more; and the Patient has the Infection of the Air to struggle with, as well as his Distemper; which often occasions the Death of those that are Sick, and sometimes that of such as visit them pretty much.

Now if fresh Air from the Hollows of the Chimney, be let into the sick Man's Room, of what degree of Heat is thought most proper, it will drive out the corrupted Air, and so take off all the Inconveniences which must necessarily be occasion'd by Air impregnated with too many poisonous Particles. Besides, since we can give the Patient what degree of Warmth we please, there will be no need of loading and choaking him up with Blankets after the usual manner.

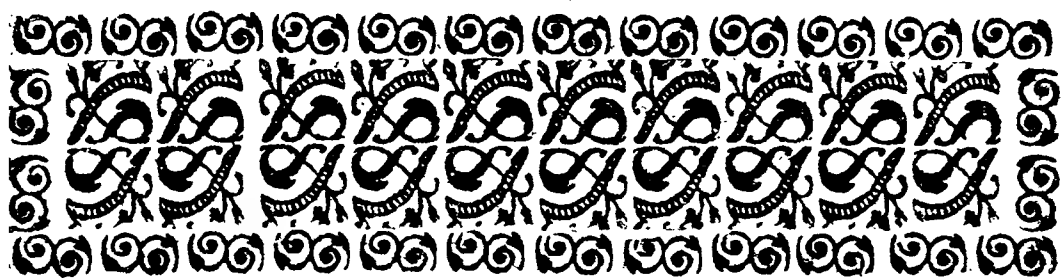

C H P A. V.

External Air thus introduc'd, can be of no ill Consequence; but on the contrary, is very proper for Health.

Some perhaps may be apprehensive that warm Air is unwholsome, which I grant of very hot Air, especially, when its heat proceeds from a mixture of heterogeneous Bodies, as Parts of the Fuel from a very great Fire, and as it is found in Air heated by Stoves, but the case is different where you have temperate Air, that changes continually; it is the fittest for Winter, or at least the most wholsome. This, Experience and Reason will easily show: It is not only certain, that the Air becomes temperate and purer, by passing through the Cavities of the Chimneys; but it is to be observ'd, that cold Air takes from us part of the Heat that is requir'd to keep us in Health, and its particles are so rigid, that the Motion which the heat of our Bodies can give them, makes

makes 'em strike so forcibly, as in some measure to break the Continuity of our Parts, by tearing our Fibres, and especially damaging our Lungs, (into which the Air rushes continually,) and so causing several Distempers.

'Tis observable, that if after a Frost the Sun shines pretty warmly on Flowers; that Heat gives such a Motion to the rigid cold Particles that were fix'd on the Flowers, as to tear and blast them. This we our selves are sensible of, when coming out of the frosty Air, we approach too near the Fire; for then we feel a sharp smarting from the sudden Motion of the frozen Particles of Water, which sometimes proves very fatal, in causing the loss of Limbs; but if we are gently warm'd, these small Isicles will be melted, reduc'd to Globules, and so blunted, as to be unable to hurt us when their Motion is increas'd by a greater degree of Heat.



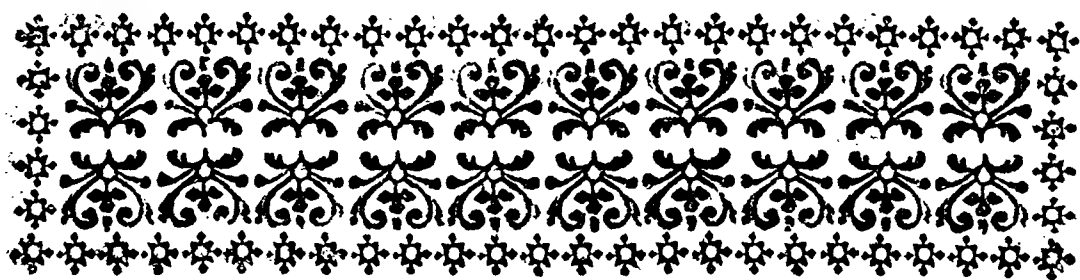

C H A P. VI.

That such as make use of Rooms warm'd after our Method, are less apt to catch cold when they go out.

SOME People have objected against the use of our new Chimneys, that going out of a warm Room into the cold Air, would make one apt to catch Cold. But Reason and Experience will shew the contrary: Do we not every Morning get out of a warm Bed to go into the Cold, and put on Cloaths much less warm than the Bed? It is a Mistake to imagine in common Cases, that People that are us'd to great Fires, catch Cold when they go into the Air, upon account of the warmth of the Room which they come out of: It is rather the Cold which they feel in the Room, when one part of the Body is cold, whilst another is almost burn'd. The irregular way of warming ones self, occasions those Inconveniences. When the Warmth is regularly communicated to

D

the

the whole Body it is much longer retain'd : A Person warm'd by our Chimneys, will be in the same condition, as those that Slide, Scate, or use any other violent Exercise in frosty Weather.

It is about nine or ten Years since I first us'd this new Contrivance, and I have not once catch'd Cold since, tho' I us'd to have a Cold two or three times every Winter before. The *Danes, Germans,* and other Northern People, who make use of Stoves, wonder at our way of warming our selves in Winter, saying, that either we sit in the cold to see Wood or Coals burn at a distance, or else by coming near the Fire, add the pain of scorching to that of the pinching Cold. They easily bear with the smothering Heat of Stoves, to avoid the other numerous Inconveniencies of an hard Winter; which our Chimneys wholly take off, without troubling us with any of the ill qualities of Stoves.

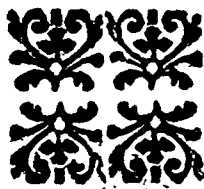

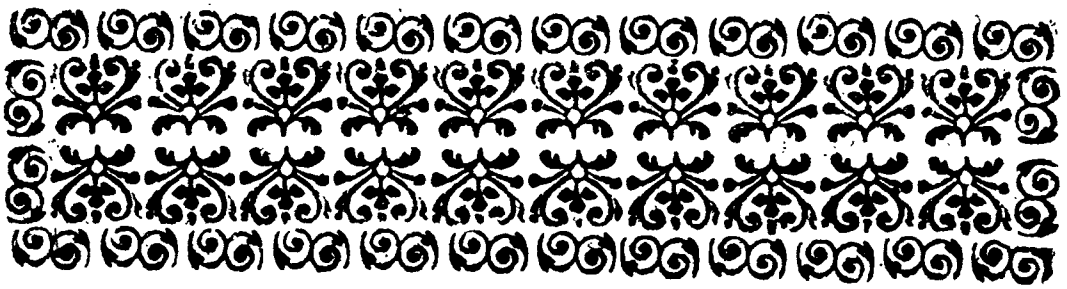

C H A P. VII.

That a little while after the Fire is kindled, the External Air gives Heat to the Room, tho' it feels as if it were cold when it comes in.
[Fig. 6.]

IN very cold Weather, as soon as you begin to kindle the Fire, the External Air passing only thro' very cold Cavities, must needs cool the Room as it comes in; therefore one might during some Moments, shut up the Hole R where it comes into the Room, till the Fire burns, and the Hollows are a little warm'd; but then there wou'd be some danger of being troubled with Smoke whilst that Hole was shut up, therefore in such a case it is better to leave it open, and blow up the Fire as soon as may be, for the bottom Plate will be immediately warm'd as soon as it beats against it; and then the Air which comes thro' the Cavities, tho' it feels cold as it comes into the Room, will not only not cool it, but even warm it;

D 2

and

and the same Air when it feels temperate, will give more Heat than the Air of the Room made to circulate, tho' this last feels very warm; several Experiments have convinc'd me of the Truth of these two Paradoxes, some of which I shall give here.

EXPERIM. I.

The Fire being kind'd in my Room, I found that my Thermometer rose whether the Hole R was shut or open, which is a sign that the Room is not cool'd by the admission of this new Air from without, tho' it feels cold as it comes in.

REMARK.

For the right understanding of this and the following Experiments, it is to be observ'd, that besides the general cause of Cold which is the Rest of the Parts; the coldness of the Air proceeds sometimes from the Quality of its Parts, sometimes from their Determination, and sometimes from both together.

1st. The coldness of the Air proceeds from the Quality of its Particles; as when they are rigid, frozen, and almost without motion, or at least mix'd with watery Particles

ticles that have those qualities, as it happens in Winter, in a hard Frost, when the Wind blows but little; this sort of Cold acts strongly on all it reaches, especially inanimate Bodies, as Rivers, Trees and other Plants; much more then when, there is a Wind. It causes a smarting also, in Animals, for then the pointed Particles like so many Needles, penetrate farther than the outward Skin.

These Particles mix'd with the Air, make the Cold so sensible in the Morning when the Sun rises, after a frosty Night, especially if there be a hoar Frost upon the Ground; for then the Sun raises those stiff Particles before he has blunted or melted them, and they fix on whatever they meet with, entering into the tender Parts of our Bodies, and so give us a more vivid Sensation of Cold, than any Cold in the Night-time.

2dly. The Coldness of the Air proceeds from the Determination of its Parts, when they have been violently driven the same way. Thus fanning, blowing with Bellows, or strongly with our Mouths, makes that Air feel cold or cool, which is otherwise warm; but this sort of Cold is only such, in respect to our selves; it is not communicated to inanimate solid Bodies, nor even to Liquids when they are shut up in Vessels;

this is the reason why the same Air that appears cold to us, does not cause the Liquor of the Thermometer to descend in the foregoing Experiment. Here follows another Experiment, which I have often made with the same success.

I have for a long time together with a pair of Bellows, blown on the Balls of two different Thermometers, whose Liquor has constantly risen, tho' it felt cold to my Hand as it came out of the Bellows. The Air was drawn into the Bellows near the Thermometer; and the Liquor wou'd rise most when the Weather was very cold, and the Liquor was but a little height above the Ball, before I began to blow.

Setting a long Tube to my Mouth, I blow'd upon my Hand, and the Air felt cold; but when I blowed upon the Thermometer, the Liquor would rise: If the Tube was added to the Nose of the Bellows, the Air would feel colder when it came out, than if I blow'd with the Bellows only; but then the Liquor in the Thermometer wou'd still rise, tho' not so high as when blow'd with the Mouth, because in the last Case the Air was heated in passing thro' the Lungs.

3dly. The coldness of the Air is occasion'd both by the quality and determination of its Parts; when those Particles being
frozen

frozen or mix'd with frozen watery Particles, and each of them singly, being almost void of Motion, they are altogether carried in a right Line, as it happens in Winter during the great Winds, especially those that blow from the North: And Cold of this Nature is always more sensible than when it proceeds only from the determination of the Parts. The difference between the Action of Cold Air upon animate and tender, or inanimate and insensible Bodies is this. That when Air loaded with the abovemention'd pointed Particles is driven violently against our Bodies, the cold sharp Particles are driven into our Flesh, and affect us strongly; but when they strike upon hard Bodies, they pass over them, without fixing to them, as we may often find that there is a harder frost when the North Wind is less, than when it is more violent. On the contrary, when hot South Winds blow hard, they cause in our Bodies a sensation of coolness; but feel hot when they blow but very gently, tho' the Thermometer rises as much in the first, as in the last case; but this will be farther explain'd when we consider the third and fourth Experiment.

EXPERIM.

EXPERIM. II.

I found that when the External Air had pass'd thro' the warm'd Cavities behind the Chimney, tho' to the feeling it was but of a moderate Heat, it warm'd the Room more, and caus'd the Liquor in the Thermometer to rise higher than the Air of the Room, when circulating thro' the same Cavities, it felt much hotter as it came out at the Hole R.

One of the Reasons of this Phænomenon, is the direction of the Parts of the External Air, which comes in with a great swiftness, and so (for the reasons given in the foregoing Remark) causes a relative Cold only.

A second Reason is, that the External Air comes into the Room in a greater quantity, than the Air taken in the Room, because it comes in swifter.

The third Reason is, that the Air of the Room after coming out of the Hole R, only warms the Chamber by mixing with it; whereas the External Air is constantly driving out the cold Air.

The fourth Reason is, that the Air from without coming in very fast, keeps the Room always full, and so hinders the cold Air from
coming

coming in under Doors, or thro' any Crannies.

The last Reason is, that when the Air constantly comes in from without; you have always more dense Air in the Room, it being more press'd: So that any Body that is heated, has a greater quantity of this warm Air about it, than it wou'd have of other Air of the same degree of Heat, and therefore is acted upon by more Particles of Air in Motion, which must consequently communicate more Motion to its own Parts.

EXPERIM. III. [*Fig. 6.*]

The Fire being lighted, I have often held the Ball of my Thermometer at the Hole R, where the External Air comes in, and it never sunk there, tho' it often rose; but if I open'd my Window, and held the Thermometer near it, the Liquor wou'd subside considerably.

The Reason of this appears to be, that the External Air was only cold by the Determination of its Parts; but the Air that came in at the Window, was colder by the quality of its Parts (for it froze then) than by their Determination: So that it must then cause the Thermometer to subside, and wou'd have cool'd the Room very much, if it had
been

been let in then, as we have explain'd elsewhere.

EXPERIM. IV. [*Fig. 6.*]

Holding the Thermometer to the Hole R, when the External Air came into the Room, so as to be lukewarm to the touch, and then holding it to the same Hole, when the Air taken from within the Room comes out, so as to feel very warm; I found the Liquor to rise no higher in this last case, than in the first; because the External Air felt only colder, upon account of the determination of its Parts; and coming out in greater quantity more parts of it encompass'd the Ball of the Thermometer, and more fine Ethereal Particles were driven into the Liquor.

From the foregoing Observations and Experiments we may conclude, that the External Air need not come very hot into the Room to warm it; if it be temperate, it is enough.

That we are not to judge of Heat or Cold only in respect of our selves; because that kind of Cold which affects us most, does not affect insensible Bodies so much; and so on the contrary.

That

That it is a mistake in those who wou'd be affected with the same degree of Heat, to have their Room just so hot as to keep the Thermometer at the same degree; because they shall be differently affected, according to the greater or less natural Heat of their Bodies at that time.

Most People have observ'd, that the Air in Cellars, feels warm in Winter, and cold in Summer; but it is only comparatively so, for the Thermometer stands at the same height in deep Cellars at both Seasons: This I have commonly observ'd, but in very cold Weather, as for Example, in the Winter of the Year 1709, the Liquor subsided to 18 degrees, which was two Degrees below *Frost*; tho' the Air did not feel cold in the said Cellar, and in a hot Summer it has risen up to 60 Degrees, tho' then it felt cold.

To give a plain Experiment, which any Body may make. Let any one having one Hand cold, and the other hot, cause lukewarm Water to be pour'd on both his Hands, and it will appear cold to one Hand and hot to the other: So that we must judge of Heat and Cold as they are agreeable to our Bodies, and not as those qualities affect insensible Objects. Therefore, tho' by the Thermometer, the Air of our Room appears
of

of a sufficient degree of Heat ; yet if it feels cold to us, we must increase its Heat.

The Reason why Air, otherwise warm, feels cold when blown briskly on any part of the Body, seems to be that by its violent Motion, it beats away those warm Particles about the surface of the Parts, which causes the Heat of our Bodies by their Motion ; or rather stops their Motion by its pressure, as we may see such an Effect produc'd when we cool hot Coffee by blowing upon it. Now in the Case of the Thermometer, the Glass stops all the gross Air, and only some very fine Particles pass into the Liquor thro' the Glass, and having more motion than the Parts of the Liquor, cause it to dilate and rise. So when the Hand is blown on, if a Glass be interpos'd between, we no longer feel the Cold ; and if our sense of feeling was nice enough we might feel a Warmth.

After the same manner, tho' the cold External Air grows warm as it comes thro' the Cavities of the Chimney, yet it must feel cold (when the Fire has not been in long,) as it comes into the Room at R ; because not having yet acquir'd a Motion capable of giving us the sensation of a moderate Heat, it affects us as blowing wou'd do ; but then when it is got a little way into the Room,
it

it spreads and loses that Power which it had at first coming out of the Hole, thro' the confin'd Passages of the Chimney : So that unless the People in the Room are, during the lighting of the Fire, so near the Hole R, as to receive the Percussion of the Air, whilst its Direction is still in a right line, they will not be cool'd by it. Now besides this, we are to observe, that this Air drives out the cold Air of the Room as it comes in, and causes the Thermometer to rise.



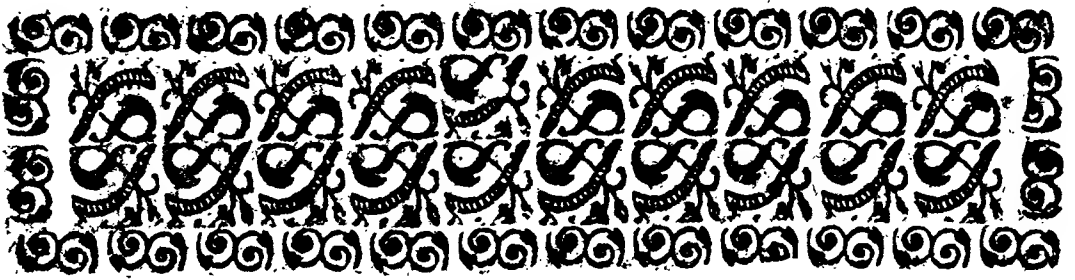

P A R T. III.

Concerning the make of the Funnel of the Chimney, for encreasing and retaining the Heat; the manner of putting out the Fire that might catch in the Funnel in an Instant, and how to make the Room continue warm after the Fire is out.

C H A P. I.

How the Hole of the Funnel at top of the House must be order'd, that the Heat of a Room may be encreas'd.

THE Winds that often blow down the Funnels of Chimneys into Rooms, shou'd have made Builders take this Matter into consideration; for when the Air of a Room comes to be pretty warm, there are at least two Columns in the Chimney, one of rising Smoak, and the other of descending Air; and tho' the Air does not always descend

descend so violently, as to make little Whirl-winds in the Chimney Corners, or as to blow the Smoke down into the Room, as it often does when the Wind is very high: Yet it always comes down fast enough to cool the Room. It is true, such Chimneys very seldom smoke; but then a Fire in them does little good in very cold Weather. To avoid this Inconveniency, the outward Hole of the Funnel ought to be small, always less than the Bore of the Funnel; and shou'd have several divisions to cut the Wind. Some have indeed streighten'd this Passage, but it has been only to hinder the Room from smoking, in which case it commonly proves ineffectual; unless with the Contrivance about it, which we shall shew in the next Book.

C H A P. II.

How to put out the Fire in the Funnels of Chimneys in a Moment, and to retain the Heat in a Room all Night long.

OUR new Chimneys indeed are less apt to catch Fire than others, because they gather less Soot; but since that may happen thro' carelessness, we must show how to remedy such an Inconveniency:

[*Fig. 4.*] To be able by ones self to put out such a Fire in an instant, we must have a Register Plate of Iron towards the top of the Funnel, so fix'd by two Wires, as either to shut up the passage wholly, or to leave it opens as you please; and such another towards the bottom of the Funnel, as we shall shew in their description in the third Book.

When the Chimney is on Fire, we move the Coals out of the Hearth, and by means of our Wire, pull down both the Register Plates; then the Smoke and Air confin'd betwixt them will so press upon the burning Soot, as to put it out quickly.

The Fire in the Funnel might be put out by pulling down only the upper Register Plate; but then the Smoke wou'd come into the Room, till the Fire was out, which however might be born with, rather than run the hazard of letting the fire burn long in the Funnel.

If there was no Register Plate at the bottom of the Funnel, to avoid the Smoak, you shou'd hang a wet Cloath before the Chimney, and instead of taking out the Coals, throw Water upon them, and then pull down the Register Plate at top: And when the Fire of the Funnel is quite out, the Register Plates must be restor'd to their Vertical Position, that the Smoke may freely come
out

out, when the Fire is again lighted on the Hearth.

These Register Plates will serve to keep in the warm Air, and keep out the Cold in the Night time, by shutting down either of them but then you must put out all the Coals; but such as do not Smoke, if you have a mind to leave any Fire. Another conveniency will be, that you will hinder the Smoak of another Chimney from being beaten down into your Room.

C H A P. III.

Of what use the Ash-Hole, and the Instrument to cover the Fire is, in order to preserve the Heat in the Night-time.

IF you have an open Cavity in the middle of the Hearth towards the back of the Chimney, about an Inch deep, it will serve to hold the Ashes that fall from the Fire, and those Ashes at Night being thrown upon the Coals, the whole Hearth will be kept warm in the Night-time; as also the Cavity under the Hearth (if there is one) thro' which you may let the Air of the Room circulate, stopping the passage of the External Air; because we now suppose the Register Plates

in an horizontal Position; and in the morning you will find the Room still warm, how cold soever the Weather is. Another way is, to cover the forepart of the Chimney, that the cold Air may not come in, or the warm go out all the time.

If you use an Instrument of Copper, Brass, or Plate Iron, made like a Box without a Lid, so large as to cover all the Fire, the Wood Coals may be put together, and the Iron Box over it and all the Ashes, and so you will have a little Fire still left in the morning. Thus the Air of the Room will in its Circulation keep the degree of Heat that it has, or acquire a greater, and taking off the *Cover-Fire* (as the Author calls it) the Fire will be easily blown up in the morning, by opening the Vent-Hole a little.



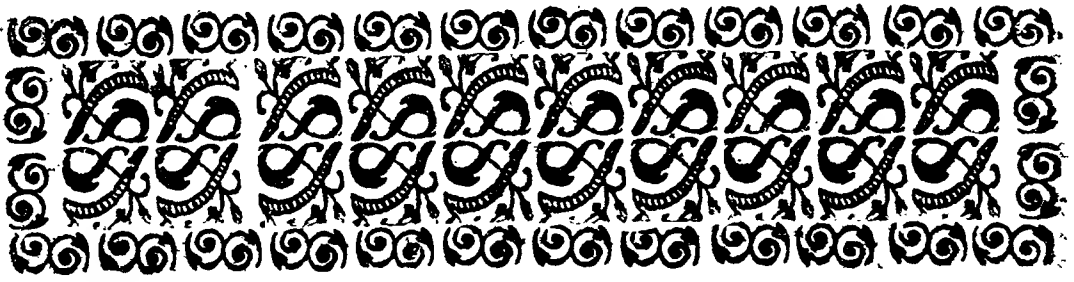

B O O K. II.

Concerning the Advantages of the new Chimneys, in order to hinder the Smoke from blowing into a Room; the Cause of which, Builders seem not to have understood, because hitherto they could not wholly prevent it.

P A R T. I.

Of Smoke, and the way to hinder it from beating into a Room, by the make of the forepart of the Chimney.

C H A P. I.

What causes Rooms to Smoke, with some Reflections concerning Air.

THE Causes of the Smoke's being troublesome to us in a Chamber, are twofold; Internal or External. The Internal Causes, that is those within the Room or Chimney,

Chimney, are first, void spaces, which are often about the Fire, which are occasion'd.

First, Because the Air being rarify'd by Heat, leaves several Internals between its Parts, where the Smoke meeting with less resistance than when they are fill'd, takes up the Place where the Air was before.

Secondly, Part of the Air of the Room goes out with the Smoke, and since the Fire is constantly causing fresh Smoke, there will at last be so much Air gone out of the Room, that the External Air will have more force against the Smoke, than the Air that is left in the Room, and so the Smoke will be driven into the Room.

Thirdly, The Air goes out of a Room, when a Door is open'd into a warmer Place, and then the Smoke will come back into the Room, upon account of the diminish'd Pressure. The same will also happen when you open a Door or a Window of any part opposite to that where the Wind blows.

This kind of Void that happens in a Room, is the chief Internal Cause of its smoaking, and has not yet been taken notice of, in order to remedy it.

Too great a quantity of Soot, and gross Air stagnating in the Funnel, when you first light the Fire; the common make of the Jams and Breast of Chimneys; and the way
that

that most of the Funnels or Flues are carried, are also internal Causes of a Room smoaking.

R E M A R K.

We observ'd in the first Chapter of the second Part of Book 1. That several Experiments shew warm Air to be lighter than that which is cold; and therefore there is no doubt, but that Air rarefied by Heat, is specifically lighter than cold Air. Now, some have objected, that when the Air in the Room is warm, as it becomes lighter, its pressure will be diminish'd, and so the Smoke will easily be driven into the Room; but we must consider, that the pressure of the Air in the Room, is help'd by that of the whole Atmosphere; and tho' the warm Air in the Room, shou'd weigh but a quarter of what the cold Air did before, yet it cannot take off above a ten thousandth or twenty thousandth part of the whole Pressure, as may be seen by the Barometer, which does not sensibly fall; when the Room is very warm; besides, the Air in the Chimney which takes up a longer part of the Pillar of the Atmosphere, is more rarefied by the Fire. Therefore this cannot be the Cause of a Chimneys Smoaking; but the abovemention'd Voids.

The

The External Causes of Smoke; that is, such as are without the Chamber or the Chimneys are, *1st.* The External Air above the Chimney, which hinders the Smoke from coming out.

2dly. The Wind which not only hinders it from coming out, but beats it back into the Funnel of the Chimney, where they also blow down sometimes with such violence, as to drive the Ashes and Coals about the Room.

3dly. The Hole at the top of the Funnel too large, or too long for its breath.

Air hinders the Smoke from going out at the top of a Chimney, *1st.* when it is too thick for the Smoke to break thro' it.

2dly. When the Chimney is commanded, tho' the Weather be very calm, and the Air clear, because as the Parts of the Air move every way, the resistance that they meet with on any one side, diminishes the spaces between them, and so both condenses the Air, and encreases its spring; then, as in the former case, the Smoke cannot so easily divide the Air to get up thro' it.

The several Cases wherein the Wind keeps back the Smoke are these.

First, When Chimneys are commanded on any side, as when they are near any great Building, near a Steeple, Tower, or

a higher House, or the side of a Mountain, &c. they are us'd to smoke, tho' the Wind is scarce sensible, especially when it comes from the side opposite to that which commands them; because the many stops that it meets with, makes it rest at top of the Chimney, and even drive into it by its encreas'd Spring, as we see all Fluids go towards those parts, where they are least press'd.

Secondly, When the Winds are violent, this Inconveniency is greater, because such Winds not only hinder the Smoke from going out, but make it go back with violence; for the Air in the Chimney, whatever Wind blows, is always more rarified than the outward Air. Likewise when the Wind blows very fast, and has a great degree of Velocity; and if its Horizontal Direction makes it slide over a Chimney's top, it is because it meets with nothing in its way, just as Water that being forc'd out of a Spring along a Table with holes in it, passes along such a Table, without falling down the Holes, whilst it has no resistance before it; but if it meets with any rub, it spreads all round about, and falls thro' the holes of the Table, and that easier than it wou'd run off on the sides, by reason of its weight; now rarified Air or the Smoke which is in
the

the Chimney, does that to outward Air, which Gravity did to the Water in the case just mention'd; that is, when the Wind meets with a rub beyond the Chimney, the rarefaction of the Air in the Chimney under it, takes off from the push upwards against the Smoke, which amounts to as much as giving it a pressure downwards.

Thirdly, When a Chimney is near enough to the place that commands it, and the Wind is strong, it may be made to smoke, tho' the Wind blows from that part where it is commanded; because the opposition that the Wind meets with, encreases the spring of the Air, and making it to be condens'd in that place, as soon as it is pass'd over the Obstacle, it pushes downwards into the Chimney, where it meets with least resistance.

Fourthly, Tho' a Chimney is not commanded, the Wind may blow into it, especially, if its Hole be a *Parallelogram*, and the Wind runs along its longest sides; and indeed, in any position of the Hole, a North Wind which commonly blows downwards, may beat into it.

Lastly, Too wide a Hole at top of the Funnel; because the Wind may easily blow into it then. These are Causes of a Room's smoaking; and we shall shew which way these

these Inconveniences may be remedied, when we have made it appear, that the make of common Chimneys causes them to smoke.

C H A P. II.

That parallel Jams or Sides, the Inclination of the Breast or part under the Chimney-Piece, and the way that the Funnels are carried, occasion Chimneys to Smoke. [Fig. 1.]

IN common Chimneys where the Jams are parallel, the Smoke easily spreads into the corners *CBA cba*, and the least Agitation throws it into the Room.

1st. Because when it is in those Corners, it is less push'd upwards, as being no longer over the Fire.

2dly. Because those places being less heated, the Air of the Room is not driven so strongly thither, and consequently does not so much push the Smoke.

3dly. Because the Air of the Room striking with more force upon the middle of the Chimney where the Heat is, it becomes more extended by Rarefaction, and pushing the Smoke still against the Corners of the Chimney, make it recoil and go back into the Room.

4^{thly}. Because the Air of the Chamber does scarce press the Smoke at all, when it is got under the Chimney-Piece; because of the inclin'd Breast *oIr*, where there is a free and heated Passage, into which it goes freely and dilates it self.

5^{thly}. Because if the Air be driven forcibly into the Chimney, as it happens when a Window or a Door is open; that Air driving the Smoke violently against the back of the Chimney, it will be reflected into the Chamber; and if it be driven from thence back into the Chimney, it will whirl about in the Corners, especially if a Wind at the same time blows down the Chimney.

[*Fig. 3.*] As for the Breast of the Chimney *oIr*, it not only gives passage to the Air that shou'd drive the Smoke up the Chimney; but when it is heated, it rarifies the Air in the Space *mior*, so much as to make it press less against the ascending Smoke, which therefore strikes near the Slope *oIr*, and being reflected, comes back into the Room; for it does not observe the same Rules as the Rays of Heat; and as it beats upon the Surface *oIr*, the greatest part of it is spread every way; as it happens to rising Liquids that meet with opposition.

[*Fig. 4.*] The Smoke is also reflected into the Chamber, when Chimneys have their
Funnel

Drawn on their wing on one side *Fires Improv'd, &c. Pl. 63*

Funnel carried bending back; for the Inclination beginning from the top of the Jam at B, the Smoke D E, which meets with resistance there, is reflected and comes down; and that more than it wou'd do if it struck higher at L; for the force diminishes as it goes farther from the Fire; but how little soever it comes down from striking against E, it comes back into the Room. For Experiment-sake, hold a smoaking Cole in the Chimney-corner just under B, and then in the middle under L, and you will see that the Smoke which strikes against E, will go back into the Chamber; but not when in the last case it strikes against L.

C H A P. III.

That Jams or Sides bent into a Parabolic form; the Horizontal Plane under the Chimney-Piece, and the Funnels carried in Curve Lines, when they are not carried directly up, are the most proper for hindering Smoke.

Parabolical Jams, and a Funnel whose fore and hind part are bent in a Curve, will take off all the Inconveniencies mention'd in the last Chapter.

[Fig. 2. & 6.] For *first*, you take off the Corners *c b a* C B A, where the Smoke used to stagnate, and then come back into the Chamber.

Secondly, This confines all the Smoke over the Fire which drives it upwards with force; and so it has more power to resist the Air at top of the Chimney.

Thirdly, The Air of the Room presses against the Smoke, whilst it is over the middle of the Fire, and so drives it all at once up the Funnel.

Fourthly, If any part of the Air that strikes upon the Jams be reflected, it goes to *F f* the *Foci* of the Parabola's, and therefore drives the Smoke thither; where it is carried up by the action of the Fire.

Fifthly, As the Air of the Room goes into the Chimney, it meets with a narrower passage, which makes it encrease its force; and much more so, by reason of the great rarefaction of the Air, which is directly over the Fire: Likewise by reason of the Horizontal Plane *o i m*, the Smoke that wou'd come back into the Room, meets with the whole stream of Air, and so is push'd up.

Sixthly, The Air from the Room having gradually more force as it comes into the Chimney, as soon as it has pass'd *m*, goes with violence into the Funnel *m L R* and

as

as it goes up makes a Wind, which forcibly carries up the Smoke.

[Fig. 3.] As for the horizontal Plane oim , it not only causes the above mention'd condensation of the remaining Air, so as to make it act more strongly against the Smoke, but also fills up the void oMR , which, as we shew'd before, was one of the causes of a Chimney Smoaking; and if any Smoke shou'd escape, and endeavour to go out of the Chimney under it, before it can be got from m to o , it is beaten back by the entering Air, whose force is greater towards mio , than lower; because the Air being already warm, and that surface warming it still more, makes it tend upwards, and strongly press against mio , so as to hinder any Smoke from coming out that way.

[Fig. 4.] Lastly, If the ~~Brest~~ be carried in a Curve; as for Example, in the Arc BeH , whose Center is taken upon the side of the Plane mio produced, as at C , you will avoid the disadvantages owing to the common way of building it in the Line $BE LH$.

For 1st. The Smoke DE , which wou'd have struck against E , will only strike against e , and with less force, as well because it becomes weaker, by being farther from the Fire, as because the Surface is less inclin'd: Thus if you suppose the Smoke to strike a-

gainst

gainst E, and from it to descend to D; whence it will go into the Room; in this case, as it does not strike against the ^VBreast-till it comes to *e*, it will only be beaten back to E, and consequently cannot go out of the Chimney downwards, but will be pushed up by the Air, and the fresh Smoke that comes from the Fire.

2dly. Supposing that only part of the Smoke that strikes against E, shou'd go down again, and be reflected as usually, the reflection will be made to G, and so may occasion the Smoke that is below EG not to rise so easily; but when it strikes against *e*, it is only reflected to *g*, where it cannot hinder the Smoke that is below it.

You may leave the ~~back~~ of the Funnel *b p h* as it is commonly inclin'd; but it is better to have it a Curve also, as you may see in the Figure.

That this way of building Chimneys must be a great means to hinder them from Smoaking, is plain, from what has been said, but if there shou'd be some case where it wou'd not be sufficient, the method that we shall give in the two other Parts of this Book, will fully do it.

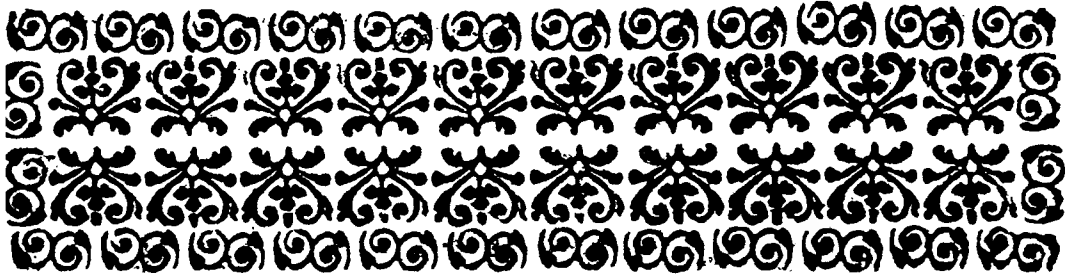

C H A P. IV.

Concerning the Vent-Hole, and the way of laying the Wood in the best manner to prevent the Smoke.

TH E Bellows or Vent-Hole mention'd in the *first Part of the first Book*, does also prevent Smoke ; not by driving it up the Chimney, as some imagine (for its direction wou'd only drive it against the Back) but by making the Fire to flame, and so diminishing the quantity of Smoke * : As also, by encreasing the Heat of the Fire, and thereby giving it more force to drive up the Smoke. If the Vent-Hole be too long, it will throw about the Smoke, more than it encreases the Heat ; therefore we shall give a particular description of it in the *third Book*.

If the Wood be round, then all the care requir'd, is to lay it so, as the Air may draw

*-Flame is only burning Smoke.

easily between to fan the Fire ; but if it be cleft Wood, you must never let the flat side incline forward towards the Room, but be either perpendicular, or rather inclin'd towards the back of the Chimney ; because the Smoke takes its direction according as it is reflected from the flat part of the Wood.



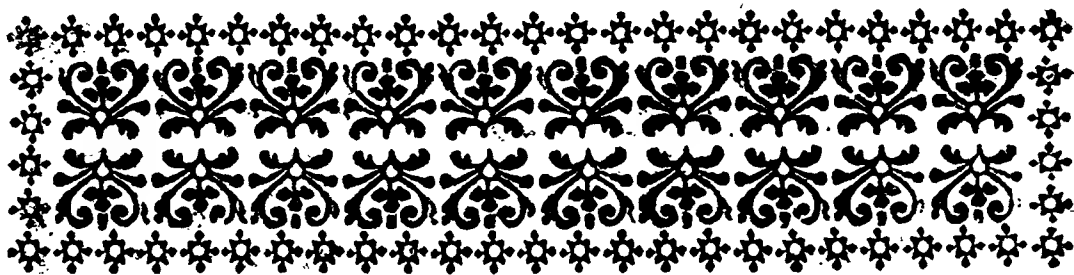

P A R T. II.

As such a Disposition of the Chimney as we have describ'd in the first Book of this Part, is not sometimes sufficient to hinder the Smoke in close places; we shall in this second Part, shew of what service the contrivance for the passage of Air behind the Back is, for hind'ring Smoke.

C H A P. I.

That the External Air, which warms a Room by going thro' the Cavities behind the Back, does also hinder it from Smoaking.

WE have observ'd in the first Chapter of the *first Part* of this *second Book*, that the Fire did continually drive out, thro' the Chimney, part of the Air of the Room, and that the most common cause of a Chimney Smoaking, was, that the Air did not come into the Room so fast, as it went

went out of it; if therefore the External Air is let into the Room thro' the Cavities of the Chimney, described in the *second Chapter* of the *second Part* of *Book 1.* there will always succeed new Air to that which goes up the Chimney; if therefore we make the Passage for the External Air open enough to let in as great a quantity of Air as that which goes up the Chimney, the Room will always be kept so full, as to hinder the Smoke from coming into the Room, unless the Wind blows down the Chimney, (and that we shall shew how to prevent) and so the internal Cause of a Rooms smoaking, which is the only cause of Smoke in places not commanded, will be quite taken off.

It may be said, that if only a fresh supply of Air be wanting, then opening a Door or a Window will do the business; this indeed will give Air, but often too much, always cool the Room, and yet often not hinder it from smoaking; for if the Door or Window which is open'd looks towards a Point opposite to that from whence the Wind blows, then (as we have shew'd before) will the Wind blow down the Chimney, and fill the Room with Smoke, even so as to drive it out at the abovemention'd Door or Window. But the Air that comes in thro' the

the

the Cavities behind the Chimney (when there is a Fire) will come into the Room, let the Wind blow from any Point of the Compass, and warm the Room at the same time. It is true, that it comes in faster, and therefore in a greater quantity, when the Wind blows upon the Hole, to admit the External Air, and slower in calm Weather: But if the Cavities are rightly proportion'd, you will not fail of the end propos'd; because when the Wind blows, there ought to come in more Air to overcome the resistance that the Smoke meets with at the top of the Funnel; and in still Weather, the Air will come in in a sufficient quantity to overcome the then less resistance. There is also required a less supply of fresh Air, when the Funnel of the Chimney is narrow, and you make a less Fire.

C H A P. II.

Of the bigness of the opening of the Sides and Cavities of the Chimneys, in order to let in as much Air as is necessary to hinder the Smoke.

WHen you wou'd only warm the Room, such care need not be taken in the proportion of your Cavities, thro' which it comes into the Room; because all the-Inconveniency

conveniency will only be, that the Room will not be so soon warm'd: But it is not so, when you wou'd prevent Smoke; making the Hollows too big, wou'd indeed do no other hurt, but hinder the Room from being so soon warm'd; but then making them too small, wou'd make them useles, because there must come in as much Air as goes out to act upon the Smoke, which otherwise wou'd certainly come into the Room. But we must not imagine, that the Hole where the Air comes in, ought to be as big as the bore of the Funnel of the Chimney; for tho' a greater quantity of Air can pass thro' the Funnel, than thro' the Hole of Communication B. [*Fig. 4. & 6.*] yet as much may come into the Room at B, as the quantity which goes out at the Funnel; because it may (and indeed does) go faster thro' the one than the other; and if it goes in, fifteen times faster for Example, then it is enough for the Hole R, to be but equal to the fifteenth part of the Hole of the Funnel; nay, and it must be less, for there does not go out thro' the Funnel as much Air as it can contain; because the Smoke goes out along with it. Besides, the faster the Air goes up the Chimney, the more is the Room emptied, and consequently the External Air meeting with less resistance comes in the faster.

If

If you wou'd have an Example to prove what I affirm ; let it be consider'd, *1st*. That as much Water shall pass thro' the Arches of a Bridge, as in the whole Channel of the River, tho' those Passages may not be equal to above a third part of the said Channel.

2^{dly}. That more Water goes out of a Vessel the first quarter of an Hour, than the second.

3^{dly}. Tho' you shou'd encrease the Hole of the Vessel during the second quarter of an Hour, yet there might go out less Water than during the first ; because the Water being more press'd, goes out with more Velocity in the first, than in the last ; so it is of the Air.

The just proportion of the Hollows according to the bigness of the Chambers, will be given in the *Third Book*.

C H A P. III.

That the coming in of the External Air to drive out the Smoke, does not hinder the Rays of Heat from coming into the Room.

IF the Rays of Heat were of the same Nature as Smoke, then indeed the Air wou'd hinder them from coming into the
G Room

Room; but whereas, the Smoke is hardly any thing else, but the moisture of the Wood reduc'd into a Vapour by the Heat; the Rays of Fire are made up of the solid parts of the Fuel darted with a great force from the Fire, which easily pass thro' the Air; and the more so, the more it is rarified: Nay, we know that they will pass thro' Silver, Iron, or Brass. Thus Sounds are hinder'd by contrary Winds, whilst the Particles of Light are darted to us with the same force, which way soever the Wind blows.

C H A P. IV.

THIS Chapter contains several Ways that have been us'd, without success, by several Architects, for preventing Smoke; and therefore the *Translator* thought it needless to trouble the *Reader* with it.

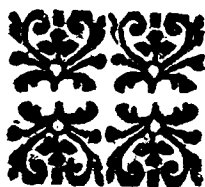

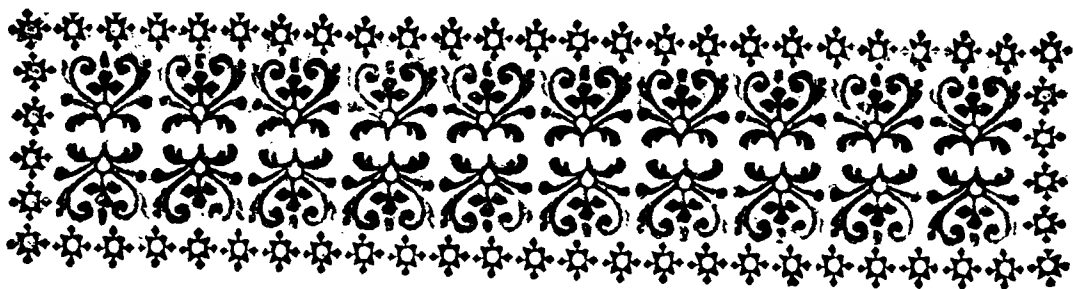

P A R T. III.

In some cases, Chimneys are commanded in such a manner, that besides what we have already mention'd, there must be a particular disposition of the top of the Funnel on the outside, which we shall give in this Part; but we must no way neglect the Helps given before; but when Necessity requires, we must make use of them altogether.

C H A P. I.

Concerning the truncated Pyramids, which may be added outwardly to the Hole at top of the Funnel of Chimneys, to help the Smoke to go out, and hinder the Wind from coming in.

Since a Chimney smokes where it is commanded, we ought as often as we can to build them up higher than the top of all the House.

[*Fig. 8.*] And because *A a* the length of the Hole at top of the Funnel, often gives way for the Wind to blow down the Chimneys, and drive down the Smoke, we must divide the said Hole into several little Squares, whose contents taken together, are to be equal to the Hole as it was without them: Then a Wind that blows in the Direction *A a*, will be as much hinder'd from going into the Funnel, as if it had come in a Direction perpendicular to it. But because making the Hole into Squares, will not enough break the Wind; (for when the Air is in agitation, it may rest upon the Flats of this divided Hole, and the Compression occasion'd by that means may force Air down the Chimney;) therefore we must add square hollow truncated Pyramids, whose Bases are bigger, and upper Holes less than the square openings of the Funnel: The Pyramids thus parted at top, tho' joining at bottom, will hinder the Wind from blowing into the Chimney, whatever Point it comes from.

First, Because by cutting and dividing the Wind: they will diminish its force.

Secondly, Because as they are terminated with an Edge, there will be no horizontal Plane upon which the Air can be compress'd so as to encrease its spring; as it happens at
top

top of those Funnels that have any flat to resist.

Thirdly, Because from whatsoever Point the Wind blows, it can find no easy entrance, the top of each Pyramid being very narrow.

Fourthly, Because tho' some Wind shou'd come in, each Pyramid being ~~larger~~ at top than at bottom, that Wind will grow weaker as it descends, and the hole of the square of the Funnel being less than the Base of the hollow Pyramid that covers it, the greatest part of such Wind will meet with resistance, and be reflected upwards.

Fifthly, Because the Wind does not equally go into all the Pyramids, and if it shou'd come in at one or two of them, it wou'd easily come out at the others.

The way that I first discover'd that the length of the Hole at top of the Funnel did sometimes cause Chimneys to Smoke, was this. I observ'd that of two Chimneys in one Apartment which smoak'd, they never smoak'd both at the same time; and found it owing to the position of the length of the Holes of the Funnels; the one being perpendicular to the other: For that Chimney did not smoke against which the Wind blow'd perpendicular to the length of its Hole. So by dividing the Hole into squares, the Wind

G 3

cou'd

cou'd only blow in the same manner, as if its Direction was perpendicular to the length of the Hole, as before. And to prevent the Inconveniency that might happen when its Direction is inclin'd downwards, I added the truncated Pyramid above mention'd; and since I have never been troubl'd with Smoke. The House indeed is very high, and the Chimney not commanded; but for such Chimneys as are lower than several Buildings about them; if these Pyramids are not sufficient, then apply the Capital which we are going to describe.

C H A P. II.

*Concerning the Capital * to be added to the above-mention'd Pyramids, to hinder the Wind from blowing into such Chimneys as are commanded, or too much expos'd.*

TH E Pyramids mention'd in the foregoing Chapter, are but part of the Contrivance to hinder Smoke; but we have given their description by it self, because upon tryal they have succeeded very well; but as sometimes there may be cases where-

* *The second Chapter of the second Part of the third Book, will make plain whatever may seem difficult here.*

in they don't sufficiently hinder the Wind, one may add above them the triangular Prism $S R Q qrs$, [Fig. 9.] either hollow or solid, as long as the Hole of the Chimney, bearing with one of its Angles Rr upon the middle of the three Holes of the Pyramids, by that means dividing those Holes in half, its Plane $SQsq$ opposite to that Angle, will be parallel to the Squares of the Holes that are Horizontal, and as broad as any of the Holes, that nothing may fall into them that comes down perpendicularly upon that Surface $SQqs$; and above that Prism may also be added, a Capital open at top, equal in length to the Prism; and divided into several other little square truncated Pyramids whose Planes $IHG ghi$, $NOP pon$ below the little Pyramids must be open enough at bottom to leave a space on each side of the horizontal Plane of the Prism, and long enough to go down below its Angle Rr , that bears upon the first Pyramid, to cover part of them without touching them. I say, that such a Capital will wholly hinder the Wind from going into the Chimney, whatever situation it has, and from whatever Point it blows; and the Smoke will come out freely. [Fig. 8, 9, 11.]

For *First*, The Smoke will meet with no stop but inclin'd Planes, along which it will slide easily, and so go out freely. 2dlv

2dly. The Wind which coming Sideways blows horizontally, will not go into the upper Pyramids, for the Reason given in the foregoing Chapter; neither will it blow into the under ones upon the same Account; and when its Direction is perpendicular to *Ll* the length of the Capital, it may even help the Smoke to go out upwards, by blowing in at the lower Holes; for the lower Pyramid making a resistance, the Wind will be made to go upwards, where it will carry the Smoke before it.

3dly. The North Winds, and all Winds that blow downwards, and so may enter into the little Pyramids of the Capital, will always find an easier passage thro' the sides *G.g, P.p* open downwards, (and will that way carry the Smoke with them,) than there wou'd be to go into the under Pyramid, whose Holes are cover'd by the horizontal Plane of the triangular Prism. The same thing will happen of the Winds which encrease the spring of the Air, by the resistance which they meet in striking against the Eminences which command the Chimneys; thus no Wind will be able to go into a Chimney that has this contrivance, neither will the Smoke be hinder'd from coming out of it.

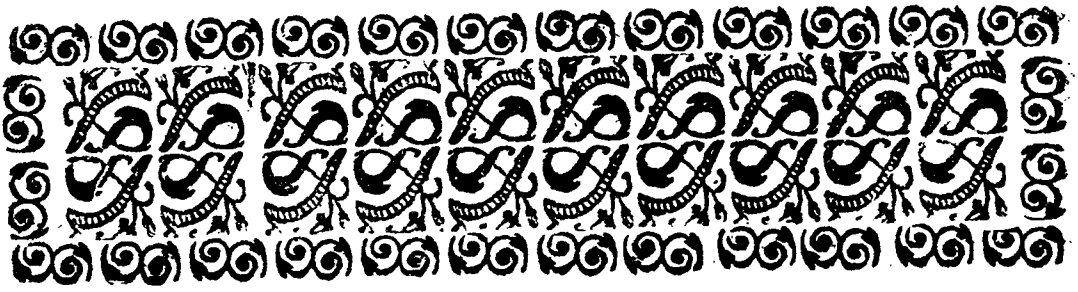

C H A P. III.

In this Chapter the Author only gives an account of the several Contrivances that have formerly been apply'd to the tops of the Funnels of Chimneys to prevent their Smoaking; but as they had no good success, we shall not take Notice of them.

C H A P. IV.

Shews how inconvenient the Smoke is, and how necessary it is to prevent it.

ALL Rooms are not equally apt to Smoke, and those that smoke most, smoke not equally at all times: Sometimes the Smoke is so violently driven into the Room, that the Fire must be put out, it being less troublesome to bear the Cold, than the Smoke. This does not indeed happen in all Apartments; but there are none but what smoke when they are very close; and if you don't bring in warm Air in Winter, you must

must either suffer the Cold, or the Smoke. Smoke makes the Eyes smart, spoils the Goods in a Room, blackens our Cloaths, and the Ladies Linnen and Lace. Besides these, there are several other Effects of Smoke which are very pernicious: Several People have been kill'd with Smoke, and the Vapour of Coals, from which that of Wood differs but little. I once had such Experience of it, as had lik'd to have prov'd fatal: I had caus'd a Stove to be made in my Closet in the Country, and having us'd it but a few Days, did not so readily find the Inconveniences of it; but one Morning the Wind blew into the Flue so forcibly, as to fill my Closet with Smoke in a moment; and drove out the Flame thro' the little Vent-Hole; I immediately took out the Wood, and put Charcoal in the Room, and so having less Smoke, I staid two or three Hours longer writing in my Closet*: as soon as I went

* It will not be improper to give an Account of some Experiments to this purpose. If you draw the Air out of the Glass Receiver of an Air-Pump, and let in Air to fill up that Vacuity in such manner, that it shall pass thro' the Smoke or Flame of Sea-Coal or Char-Coal, and drive it before it as it rushes into the exhausted Receiver; that Air will be so vitiated, as to kill a Cat in a very little time, if taking off the cover of the Receiver, you put the Cat into the Receiver filled with this Air, thus impregnated with the Steams separated from the Sea-Coal or Char-Coal; those of Char-Coal being always found most-pernicious.

out I was taken with such a Giddiness in my Head, Qualms and Fainting, that I easily guess'd that if I had staid a longer time in the Closet, the consequence of it wou'd have been fatal. Therefore, tho' we may not at first feel the Inconveniency, yet at long run we shall find the pernicious Effects of drawing Smoke into our Lungs or Stomach, or Air impregnated with Smoke.



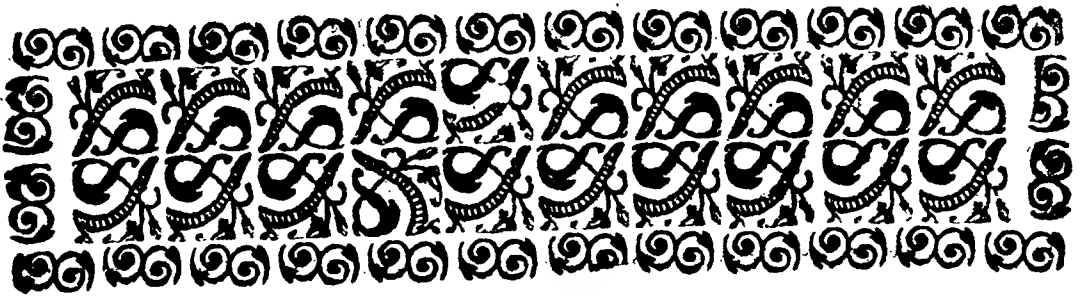

The Conclusion of the two first Books.

TH E Reader may have observ'd in this second Book, that all the Means made use of in every case to prevent Smoke, were the same that were mention'd in the first Book, for the increasing of Heat. The Parabolical Jams or Sides; the Cavities behind the back of the Chimney, for introducing and warming the External Air that rushes into the Room; and the Contrivances in and at top of the Funnel to keep back the Wind, all serve to hinder the Smoke, as well as increase the Heat; and those that are properest for preventing one, are also fittest to prevent another ill Effect of the common Chimneys.

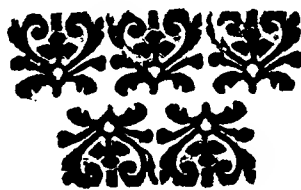

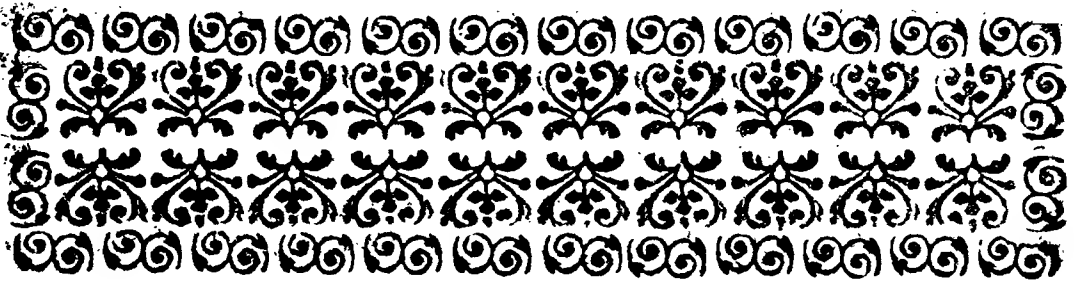

B O O K. III.

The former Books only shew'd the use of our new Chimneys, by giving a slight Description of them; but this third Book is very particular in order to instruct the Work-man how to make them easily.

P A R T. I.

Gives the Construction of the Hearth and Jams of the Chimneys, and of the Hollows that must be left behind, as well to increase the Heat, as to hinder the Smoke.

C H A P. I.

Of the Model, by means of which the Work-man may give Chimneys that Sweep or Curvature which they ought to have.

WE here suppose the Chimney four Foot wide, and twenty Inches deep; tho' we shall also give the Proportion for
H Models

Models, when the Chimneys are larger or less.

[*Fig. 12.*] Take a Board $ABba$ four foot long and 20 inches broad, whose sides are all square to one another; from the middle M of the side Bb mark MC eleven Inches, and from C , the length CG of four Inches; draw the Line GA on which take $GH = 5$ Inches, from H draw HP square or perpendicular to GHA , joyn HC and upon I the middle of that Line draw IP perpendicular; then from the Point P where it cuts the Line HP , as your Center with the distance PH or PC draw the Arc HC ; then do the like on the other side, where you have the same Letters in a small Italick Character.

Within an Inch of the side $BCcb$ of the Board, mark the Rectangle $KktT$ a foot long, and 8 Inches broad, its middle being over against M ; and within three Inches of KT , draw another small Rectangle Z three Inches long and $2\frac{1}{2}$ broad, whose middle must be over against the middle of KT ; cut out the Stuff where those Rectangles are drawn, and having also cut the Board away along the Line $AHCMcha$ you will have the Model for the Back and Sides of the Chimney.

We

We have suppos'd the Breadth Aa of the Chimney to be four feet; but if it was but $3\frac{1}{2}$ then CG shou'd be taken but $= 3\frac{1}{2}$ Inches, and but 3 Inches if Aa be only a foot wide, GH $4\frac{1}{2}$ Inches in the first case, and only 4 in the last.

In all these cases you may make gb equal to gc , and draw perpendicularly from those two Lines, cp and bp and about p the Point of their Interfection, with the distance pc or pb , draw the Arc cb , and do the same thing on the other side.

If you wou'd have the sides AHC , abc which are nearly parabolical to be strictly so, then each side must be a half *Parabola*, having Ff for their Focus's; [*Fig. 2.*] the Back between the Vertex of each being left streight, and any Workman that can but draw a *Parabola*, may fit the Model; tho' there is no need of being so exact; because, since the whole design of the Parabolical Jams, being to throw all the Rays of Heat into the Room, the same Effect will be produc'd by sides that are nearly so.



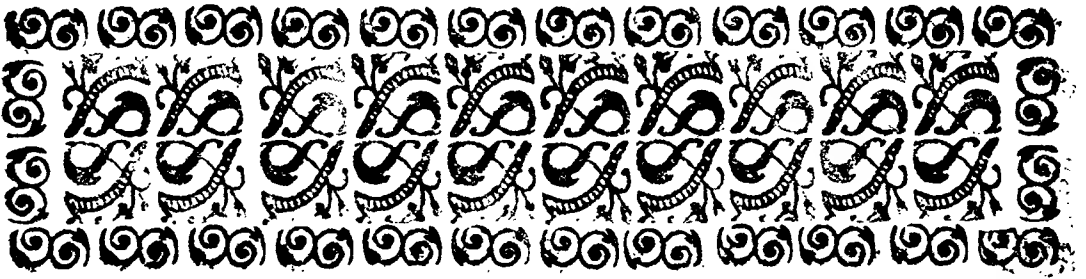

C H A P. II.

First Construction for the simple Chimneys.
[Fig. 6.] 2

1st. **T**HE Model *AHC cha* for the sweep on the inside of the Chimney, being drawn after the manner shewn in the forgoing Chapter, must be laid on the Hearth, or the place design'd for the Hearth of the Chimney, in such manner, that the Points *Aa* touch the forepart of the Jams or Sides, which must be raised up along *AHC cha*.

2^{dly}. The lower part of the Breast or place under the Chimney-Piece must be an horizontal Plane, reaching within 10 or 12 Inches of the Back; for the Funnel must be left no bigger, as may be seen in *Fig. 3*.

[*Fig. 4.*] 3^{dly}. If the Funnel does not go straight up, the sides of it *BcH*, *bGb* must be made parts of a Circle from *B* and *b* the top of the ~~Jams~~ as high as the Ceiling *Hb*; continuing a Line on the horizontal Plane
at

at bottom of the Breast, ~~to that it may be~~
~~equally distant from C~~ and ~~D~~, from a Point
taken upon it behind the Back, may be drawn
the Arc *BeH*.

These three positions of the Jams, the
horizontal Plane, and of the Funnel which
must also be us'd in all the other Chimneys
of which we shall make mention, are for the
first Construction, which, tho' it seems ve-
ry little to differ from common Chimneys,
gives abundantly more Heat without a big-
ger, nay with a less Fire; as we have shewn
in the second and third Chapters of the first
Part of the first Book.

[*Fig. 6.*] You may, if you will add the
Ash-Hole *KktT*, and the Bellows *Z*, the
Construction of which we shall give in the
10th Chapter.

This first Construction may be effected,
with very little Expence in all sorts of Chim-
neys, and very little Trouble or Alterati-
on; but then it encreases the Heat only by
reflecting more than common Chimneys;
and it wou'd not always be sufficient to pre-
vent Smoke in Rooms that are apt to smoke,
tho' it will cure several smoking Chimneys;
as we have shewn in the *1st. Chap. Part 3.*
Book 2.

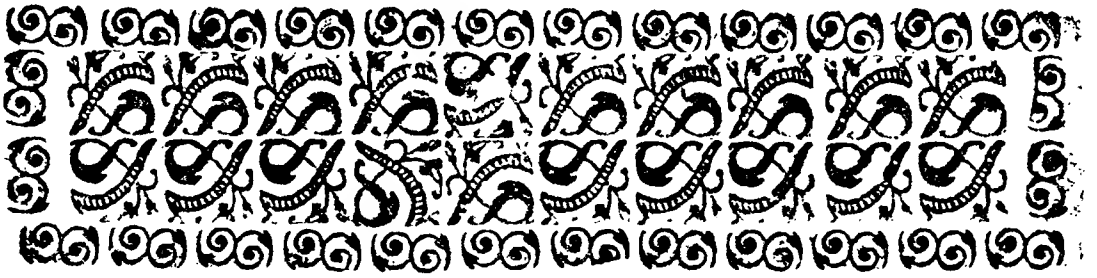

C H A P. III.

Second Construction, being that of Chimneys which supply us continually with new Air, which is warm'd in passing thro' Cavities behind the back of the Chimney.

TH E foregoing Construction differs so little from the common way of building Chimneys, that the Workman will find no difficulty in effecting it; but the same cannot be said of the Construction which we shall give in this and in the following Chapters.

To make it the easier, we shall first describe each Piece by it self, and then shew how they must be joyn'd and laid.

[*Fig. 13.*] The first Piece which is very simple, must be a Plate of Iron or Brass *HI* about four foot long, and $3\frac{1}{2}$ feet high made up of several Sheets joyn'd together.

Now as the Flame continually beats against the middle of this Plate towards the bottom, and the Coals always lie against it; you

you may in that place add a small Plate O D F I L of the shape represented in the Figure, having round about it a little Frame of Iron half an Inch thick ; the whole being screw'd with screws that have their Nuts fix'd behind, that you may at any time take off the Plate, and fix another, without altering the Chimney.

The other Pieces are to be little strips of Plate Iron 5 Inches wide, and about 10 Inches shorter than the height of the great Plate to which they must be fix'd behind, along the Lines H I , C X , c x , h i , in such manner, that the first shall begin from the top, and end 10 Inches above H ; the second must begin at bottom, and come 10 Inches short of the top, the third must be as the first, and the fourth as the second, as you may see in the 21st. *Fig.*

[*Fig. 13.*] Sometimes it will be well to have four of the narrow long Plates between H and h , but now we suppose only two, in order to make the thing the more intelligible, and that it may be the more easily perform'd by the Workman ; for when a Man understands it, and can do it in this simple manner, he may easily go on to a more complex'd Construction.

These long Plates being thus fix'd, set the middle M of the Plate over against the middle
dle

dle M of the Model A HCM *cha*, then bend it round according to the Model in such manner, that lifting the Model up and down in an horizontal position it may fit the Plate (as it stands upright) from the top to the bottom; and you will have the second Construction, which you must lay or fix in the following manner.

The Way of laying or fixing the second Construction for a Chimney.

Before we lay this Chimney or the others, whose Constructions we shall give in the following Chapters, there must be made a square Hole of about a foot in the nearest Wall that looks towards the Street, or into a Court-Yard, or any where out of Doors, about the level of the lower part of the Floor, or even below that; to this Hole, if necessity requires, joyn a Passage or Canal thro' which sixty or seventy square Inches of Air may pass; this Canal may be carried in the Wall, or between the Joysts under the Floor, or bearing against the Wall in the Room, as shall be thought most convenient to bring the External Air into one of the Cavities behind the Chimney.

If it be thought needful or most convenient, Air may be brought in at top of the
the

the Funnel of the Chimney, making within it a small Canal, which must be carried down a little way below the Hearth, and so made to turn up into the first Cavity; but then such a Channel must be made when the Chimney is first built, otherwise it wou'd be very difficult. The passage for External Air being made, set upon the Hearth of the Chimney, or on the place where it is to be, the Model *AHCM cha* [Fig. 19.] Between the Jams, or the places where they are to be; the forepart *Aa* must be in the same Line as the Chimney-Piece or forepart of the Jams; along the Model must be drawn the stroke *AHC cha*, on which must stand the great Plate on the inside of the Chimney: Four Inches beyond the first Stroke or first Line draw another (where the Cavities are to be) parallel to the first, to be taken in part out of the Wall of the Back if possible, out of which you must dig it to the height of three feet and a half; but if the Wall wo'nt allow it, bring forward the Model, so as to leave behind it four Inches over against the Line *Cc*, in that case also the Jam must be made forwarder in the Room, and if there be occasion, the forepart of the Funnel may also come forwarder into the Room; you must fill up the spaces *AHM*, *abm*, and those that are beyond the second Curve

Curve Line MN, *mn*, but without stopping up the passage Dy, thro which the Air must go into the Cavities behind the Chimney; then in the Bottom and Sides must be made little Trenches as M, N, *n*, *m*, to sink into them, the long Plates which are behind the great piece; and from the place where the outward Air comes in behind the Chimney, make a little Channel HZ which ends in a Cavity, that must be made under the Vent-Hole or Bellows Z, about 12 or 15 Inches from the Back forwards; the Construction of this Vent-Hole is given in the 10th Chap. This Cavity thus order'd, the Chimney must be laid; that is, the great Plate set upright in such manner as to fit to the Model all the way on the inside, and the long Plates on the backside must fit into the Trenches made for that purpose, and there must be four Inches between the great Plate and the Wall: Then all the places must be close stopp'd where the Air can go in or out, except the Cavities themselves and the lower Hole D, and the Hole R or *r*, which must be left above.

If you find it difficult to fill those Trenches, after the long Plates are got into them, then before you place the whole piece, fill the Trenches with soft Plaister or Mortar, that the long Plates may as they are thrust

thrust in be fix'd, and that way they will be clos'd.

The whole difficulty may be avoided, and several other Conveniences be had, if you shut up those Plates by a great Plate parallel to the first; for then it will make a sort of a divided Box, which it wou'd be easy to lay and Seal; and if occasion be, to take it off and carry it to another Place: The manner of doing it easily, may be seen in the sixth Chapter.

If the Cavity behind the back of the Chimney is not taken in the Wall, it will be proper to nail a great piece of Plate-Iron at the top of the great Plate, to shut up the back Space, or to hold the Mortar that is laid on to shut it up.

[*Fig. 6.*] The Chimney being thus laid and seal'd or clos'd, from whencesoever you take your External Air, you must bring it quite to D, where it will go up into the first Cavity, go down the second, then goes up again thro' the third, out of which it will go into the Chamber thro' the Hole *r*, where there are only three Cells. We shew'd in the *3d. Chap. of Book 1. Part. 2.* the reason of this course of the Air.

But because the Air sometimes will not acquire a sufficient degree of Heat by going only thro' three Cavities; you may as we have

have already shewn, make five, by adding two more long Plates, and placing them as you see in the 21st. *Fig.* and the Air will go thro' the Cavities, rising in the first, third and fifth, and descending in the second and fourth. There might be seven Cells, if the Plate behind the first and great Plate, or the Cavities be continu'd quite to the fore-part of the Chimney; for ten Inches distance between each long Plate is sufficient for common Chimneys; but the Cavity must be no less, that there may pass about 40 square feet of Air; when there is not room for this proportion, make the second Cell a little bigger than the first, and the third bigger than the second, and so on.

The Lines which are drawn winding in the 21st. and other figures, shew the coming in, the course, and the going out of the Air.

That the Air which is to pass thro' these Cavities may go into the Room but when you wou'd have it, and but in such quantity as you wou'd have it, there must be sliding Boards, or Doors at the Holes R or r, where it comes into the Room, which may be more or less open as you see fit. You may also let in the Air at those Holes so as to have it hot or cold, or temperate in any degree; as we shall shew in the 9th. *Chap.*

If

If you wou'd burn Wood, the Billets standing upright, as I am told the *Swedes* do, you may make the Chimney an exact *Parabola*, which will be of use where you must have very narrow Chimneys, as in Corners.

C H A P. IV.

Third Construction, by which the fresh Air which comes constantly into the Room, is heated both behind the back of the Chimney, and under the Hearth.

IN the foregoing Construction, the Air is only warm behind the Back and Sides of the Chimney; but it may still acquire much Heat in going under the Hearth.

[*Fig. 13. First Piece.*] To have the first Piece of this third Construction, you must lay the Model (which we suppose rounded and cut thro') upon a Plate of Brass or Iron, a little longer and a little broader than it is; then first draw the Curve Line *AHCMcha*, round about this Model, and then another parallel to it about $\frac{1}{4}$ of an Inch, beyond the first Line, as you see it pointed in the Figure, you must also scribe or draw *KkT* the place for the Ash-Hole, if you

I

wou'd

wou'd have one, and a little forwarder one for the Vent-Hole z ; those two places must be cut thro', but the Ash-Hole, if possible must be sunk an Inch. In the 10th. Chap. we shall give the Construction of the Trap-Door, which must be fix'd to the Hole Z , where the Wind is to come in. Lastly, You must fold downwards to a square all the part which is beyond Aa , and so you will have the first Piece.

[*Fig. 13. Second Piece.*] The second Piece is a Plate of planish'd Brass or Copper $ABEG$ *geb a* as long as the round of the Back and Sides of the Chimney, that is, in this case of about six Feet, (it might be of Plate-Iron, and only four foot long) and three foot and a half high; fold the lower part and the two sides to a square a little more than the breadth of a quarter of an Inch: Set off upon each side the height $AB ab$, of 2 Feet and 8 Inches each; when the Plate is 6 Foot long, and covers the whole compass of the Chimney, take off the two little Rectangles BEG, beg ; in the middle of this great Plate, put a little Plate with its Frame, as we said in the foregoing Chapter.

You must also cut out little Plates five Inches broad, some two foot and a half, and some about a foot long, as may be seen in *fig. 18*, to make Partitions ~~under~~ *behind* the second Piece,

Piece, and below the first; and then you will have all the Pieces fit to finish the Chimney.

To joyn them together, turn the second Piece *GEHAM abeg* upon the Model *AHCM cha*, which you must hold to it in such manner, as to have its middle *M* answer to the middle *M* of the second Piece, and then set the Model upon the stroke *AHCM cha* of the first Piece; set up the second upon the first about the Model, in such manner, that its concave side may every where touch the convex part of the Model.

As what is folded along the Line *ACM ea*, is but little above a quarter of an Inch, and that which exceeds this stroke of the Model in the first, is about three quarters of an Inch, there will be almost half an Inch of Stuff exceeding the other Pieces which you must fold back again, or turn up over the lower end of the second Piece, putting here and there Rivets, and so you will have these two Pieces so fast to one another, as to leave no passage for Air or Smoke, which ought to be taken great care of: When these Pieces are made of several Iron Plates, the Rivets must be very near together; but if they are Brass or Copper Plates, they shou'd

I 2

be

be folder'd with hard Solder, or at least, those that make up the second Piece.

[*Fig. 13.*] Lastly, You must fix upon the square behind the second Piece on each side of the middle M, two Partition-Plates 5 Inches wide, at least 5 Inches distant from M, and the two next 15 Inches distant from it, that there may be 10 Inches between each; fix such Plates under the first Piece that makes the Hearth, which must joyn to the others in the shape of a Square that is in a right Angle. The first and the third of them must go so far, as the Line *A a*, which is the forepart of the Hearth; and the second and the fourth must come as far short of the top of the second Piece, *viz.* about 10 Inches. If you wou'd have the Course of the Air be longer, it is but adding two more partition-Plates, to have 5 Cells as in *fig. 22*; you may have seven if you will.

The Partition-Plates under the Hearth, may be laid parallel to the back of the Chimney, and lye from one Jam towards the other, as in the *4th.* and *23d.* Figures. Those likewise behind the Back, may have an horizontal position as in *fig. 23*; which may be more easily done, if the Back be streight, and the Jams parallel as in common Chimneys; it is more difficult, if the Back and Sides are rounded after our Method given; but

but that is not the reason why we do'nt use them so, (for they might be fix'd along that part of the Back which is streight,) but the perpendicular Situation goes part of its Journey descending, as may be seen in the 22^d. *fig. &c.* and so is longer in passing thro' the same number of Cavities.

Tho' those several positions of the partition-Plates be easy to be understood by a sight of the Figures; yet it will be best for the Workmen to use themselves first to one position of them, till they can make them easily; or at least to have Models, tho' but of Pastboard.

How to lay the third Construction for a Chimney.

When you have made the way for the External Air, after the manner mention'd in the foregoing Chapter, and have digg'd out the space in the Back-Wall, you must also dig in the Hearth to the depth of 4 Inches, and besides that, make Trenches to fit the partition-Plates into; then from the Plane where the External Air comes in under the Hearth, make a small Channel HZ which must end in the Cavity that belongs to the Vent-Hole Z. The Hollows being thus prepar'd, lay or fix all the Plates now joyn'd, in the manner before shewn.

The Chimney being laid and made close, and the External Air being brought to the Hole D, it will go winding thro' the Cavities in the Direction represented by the winding Lines, *fig. 22* and *23*.

What we have said concerning the Hole R or r, for the last Construction, must also be understood of this.

C H A P. V.

Fourth Construction, whereby the fresh Air coming continually into the Room, acquires Heat behind the Back under the Hearth, and also under the Mantle-Tree or fore part of the Breast.

BEsidēs the Cavities mention'd before; the Air may go thro' another made over the Horizontal Plane at the bottom of the Breast.

[*Fig. 13. 1st. & 2d. Piece.*] The two first Pieces for this fourth Construction will be drawn, cut and put together as those of the foregoing, mention'd in the last Chapter; but you must have only four Partition-Plates behind the second Piece, in the manner shewn by the prick'd Lines, HI, CX, cx, hi.

[*3d. Piece.*]

[3d. Piece.] To have the third Piece, lay the Model $AHC\ cha$ upon a Brass or Iron Plate $BG\ gb$, which is to be about half an Inch forwarder than the Edge Aa ; draw along AH a Line BE equal to BE of the second Piece, and at the other end along ab another be equal to the first; from the Points E and e , you must raise two perpendiculars EG , eg upon the Line Ea , equal to the Lines EG , eg of the second Piece; draw a Line from G to g , and another from B to b , and cut the Piece within half an Inch of the Stroke $GEB\ beg$, and fold it up square along the Line Ee , you must also fold upwards, what is left beyond the Line Bb , and downwards what is beyond the Line $GEB\ geb$.

The two first Pieces being joyn'd, fix upon the Voids BEG , beg of the second Piece, this Third, whose edges BEG , beg being folded, will serve to Nail along BEG , beg .

You might with another Piece folded also square, (tho' it were but of Tin, or very small Plate-Iron) shut up the upper and forepart of this third Piece, and fix them together with Rivets; to make a small Canal of it; and then fine Mortar might be laid over the upper and forepart of it, which wou'd make it more solid, and cause
the

the Air to be more heated in passing thro' it.

How to lay the fourth Construction of a Chimney. [Fig. 24.]

You must dig the Cavity in the Back of the Chimney and in the Hearth, after the manner that we have shewn in the foregoing Chapter, for the Construction there mention'd; then take away whatever is solid under the Mantle-Tree or behind it if it be low, to make way for the Canal that must be put there; then the Chimney must be laid, as we have shewn in the foregoing Chapter; you may also fix this square Canal to the Stone or Timber at the bottom of the Breast; bring in the External Air as far as the Hole D, from whence it will go into all the Cavities, and go in the Direction represented by the winding Line; that is, it will first go up the Cavity HCXI, from whence it will go thro' GQ E into the Passage behind the Mantle-Tree (which Passage is taken away in the Figure, the better to represent the way of the Air) and so go from SEBL, to *sebl*; from which it will go out thro' *geg*, then descend thro' *ihc*, and go under the Hearth, afterwards rise thro' Cc into the middle Cavity cCXx, whence it will go out thro' one.

one of the Holes R or r, or if you will, thro' both at once; little Doors are to be fix'd to the Holes, to proportion the quantity of the Air which comes into the Room. We shall give a description of them in the Ninth Chapter.

[Fig. 13.] Those that wou'd still encrease the Effect of this Chimney, may easily (especially when it is something large) do it by making the way of the Air longer; one need only put two partition-Plates instead of one, in the space CA, ca, and leave a space of four Inches round about the Chimney, and you will have seven Cavities about the Chimney, besides those under the Chimney-Piece, and under the Hearth; which last may be still divided, but all this wou'd make the Chimney too complex and chargeable; the next Construction is much more simple, and gives a sufficient Heat.

C H A P. VI.

The fifth Construction is more simple than the foregoing, where the Air only passes behind the back of the Chimney, and is heated faster than in the other Constructions.

IT was requir'd for the foregoing Constructions, to have the Pieces of Brass or Copper,

Copper, but they might be made of Plate-Iron; but it wou'd be difficult to make them so exact and clever, especially the great Plate *ABG gba*; such great Plates of Iron are not manag'd and work'd so easily, when they are made of many Pieces; for one cannot get such large Plates of Iron, as one can of Brass or Copper; and there wou'd be so much Work, that the Cost wou'd be as much as if Copper Plates were us'd.

But it is otherwise in this fifth Construction; for it may be made wholly of Plate-Iron, and be as exact as if it was of Copper, be much more solid, and last longer; for you may find Plate-Iron much thinner than Plates of Copper, and it will much better bear the Fire.

In this Construction it is not necessary to have Cavities under the Hearth, nor in the sides of the Chimney, and consequently not to face them (unless you have a mind) with Plate-Iron or Copper; besides, you need not have any Canal under the Mantle-Tree.

To give the External Air sufficient Heat for warming the Room, you are not only to have in the Back of the Chimney a Box or Case, divided within by long partition-Plates, which make up three or five Cells, having a communication one with another, which

which make a sort of a recurv'd Canal with several turnings.

Here follows the description of every Piece, and the manner of putting them together, for the benefit of the Workman.

[*Fig. 28. 1st. Piece.*] The first Piece must be a piece of strong Plate-Iron 3 Foot or $3\frac{1}{2}$ foot high, and at least 2 foot wide, made of two Plates joyn'd, (for you can hardly get one Plate of that bigness) and divided in two places, as you may see in the first Piece of *Fig. 28*, where the prick'd Lines shew where the Pieces must be joyn'd, as they also do in the other figures.

The *2d. 3d. 4th. and 5th. Pieces* *CGg, Efe, LHh, Mmx*, are four little Plates two Foot and three Inches long apiece, (supposing the first Piece only three foot long) and five inches wide, besides what is left over and above to turn up for joyning them together, as is shewn by the prick'd Lines; when those little breadths are turned up square, let them be fix'd to the fifth Piece along the Lines *CG, fE, LH, Mx*, in such manner, that the Letters in the one, may correspond with the same Letters of the other; these need not be of strong Plates, any more than the following Piece.

Lastly, The sixth Piece must be a Plate *GgXxmc*, three foot nine inches long, and
two

two foot wide; its end Cc , Xx must be fix'd to the two Ends Cc , Xx of the first Piece, and to the other Pieces where it is to touch them; but at first you must only fix the second and third to the first, then the sixth; then the fourth and fifth, because that way one shan't hinder you from rivetting the others; all these Pieces thus united, will make up the Box $Cg Xxmc$, which is required for this sixth Construction.

The partition-Plates and Cells are here vertical, but they might be horizontal, tho' they are better in the first situation, for the reason given in the fourth *Chap.*

[*Fig. 21.*] The first Piece or fore-Plate, might be made 3 foot and some inches wide; then fixing the partition-Plates in the manner and at the distance before given, there will be left on each side the Breadth CH , cb of about 7 or 8 Inches; at the sides of the Plate fix two little Plates the whole length, about an Inch wide, or else turn down the Plate it self, in order to make it keep its figure and the better to close it when the whole Box is laid, as we shall shew; and by that means you will leave two more Cells, which will still give more Heat to the Air; because having a longer journey to go, it will be longer encompass'd with Heat.

This

This Box may if you will, be of cast Iron, if you make it of two pieces, one of which has all the Partitions, and so join them together with Screws. The second and third Construction may also be of cast Iron, especially when you have but 3 Cells.

How to lay the Box, for the fifth Construction of a Chimney.

[Fig. 21. & 29.] First of all, lay the Model *ACca* upon the Hearth, to draw the curve Line *ACca*, and to mark out the Ash-Hole *KTtk*, and the place for the Vent-Hole *Z*: Then dig in the Wall the depth *CNnc* of about five Inches, and of the same height as the divided Box; or if the Wall won't allow it, bring forward the Jams if the Chimney is not deep enough, that you may have behind *Cc* (the Back of the Chimney) a Cavity *CNnc* about 5 Inches deep; dig also the Ash-Hole in the Hearth about 2 Inches deep, and quite as far as the bottom or back part *Nn* of the Cavity made for the Box; bring a little Canal *HZ* under the Hearth into the Cavity *Z*, which is under the Vent-Hole or Bellows, then put the Box into the Cavity made in the Back of the Chimney, in such manner, that the bottom of it *Cc* may be rais'd about 2 Inches

K

ches above the Hearth, and a space of about half an Inch may be left behind the Box quite to the top of it, (as you may see in *fig. 26.*) and go out about *Xx*, where the little openings *V V V* (*fig. 21.*) must be left; this Piece thus laid must be clos'd every way, except at bottom, where it must not come beyond the Line *Cc* drawn upon the Hearth; you must fill up the sides of the Chimney along *AHC cha*, that it may have the shape of the Model; fix the little Trap-Door, whose Construction we shall give in the *10th.* Chapter, over the Cavity *Z*, and this Chimney will be finish'd if you wou'd have but three Cells. But if you have made the forepart of the Box of the whole breadth *HCch*, in order to have five Cells, [*Fig. 28.*] dig out of the Wall also the Cavities *HP NC, hpnc*; [*Fig. 29.*] Give the Plate the shape of the Model, from *H* to *b*, [*Fig. 21.*] and lay the Box as we shew'd; the last partition-Plate on each side, together with the part of the fore-Plate *CH ch* which exceeds the Box, with the surface of the Wall *HPN hpn* will make the two other Cells, behind which the Heat is not to pass, but only behind the other three.

This Chimney being thus laid and seal'd, the Air that is brought from without, in the manner shew'n in the third Chapter, being

ing come as far as *cM* [*Fig. 21.*] will go into all the Cavities of the Box *LHEFG*, and go out thro' *GX*, to go into the Room thro' *R*, when you have only three Cells; but if you have five, the External Air going in at *Dy*, will go thro' *G, E, H, M*, to come into the Room thro' *r*, as the winding-Line plainly shews; you may let it come into the Room thro' the other side *R*, and even thro' both at once; if you wou'd have cold Air also come in at *r*, you must bring that Air from the Vent-Hole as far as *ba*, and from thence as far as the Hole; the prickt Lines in *fig. 30.* shew the way.

You must, as much as you can, contrive it so, that the External Air does not immediately go into the Box, especially when it has but three Cells, but let it wind a little first.

Tho' in this Construction the Air has not so many windings, as in those mention'd before; yet it acquires as great a degree of Heat as in the fourth, and a greater than in the second and third; because the Heat that goes behind the Box, warms it on that side, and the Flame and Fire before; and as the partition-Plates are between, they are heated at the same time; so that the Air which in the other Constructions receives its heat only from the forepart of the Cavi-

ties, is here heated from all Parts, as passing thro' a Canal encompass'd with Heat; and if you suppose that it takes up eight Moments in going thro' the Cavities in the other Constructions, and only four in this, it will here acquire three or four times more Heat every instant: So it will here acquire as great a degree of Heat in two Moments, as it does in four or six in the other Constructions.

If to this Construction you add a Cavity under the Hearth, as in the 3^d. and 4th. thro' which you bring the Air, before it goes into the Box, you will increase the Heat; as also, if you face the sides of the Chimney with thin Copper, or even with Tin Plates.

Cold Air may be brought in one of these ways, which we shall give in the ninth Chapter.

The fifth Construction is so simple, easy and cheap, that I reckon it will be the most common; it is that which I make use of at present.



Hearth, which is suppos'd to have been digg'd four Inches deep.

Now if the Air begins to come into the Cavities thro' DAH, and goes under the Hearth thro' AHba, it will come up thro' *habi*, go down again thro' *ihc*, then (if there be no Cavity behind the Mantle-Tree) go into the second Cavity under the Hearth *ch HC*, go up H CX, from whence it will go out to go into the Room thro' R, after it has acquir'd Heat in all the Cavities.

But if there be a passage behind the Mantle-Tree, after the Air has pass'd from D thro' the Cavities HA *ah*, *habi*, it will go thro' *igq* into the Canal *bes*, SFB under the Mantle-Tree, go down from it thro' IXCH, to go into the second Cavity HC *ch* under the Hearth, then to rise into *chx*, and so go into the Room thro' *r*; the space AHIB being of no use, may be left full.

You see that this sixth Construction differs little from the first, third or fourth; and so that they may be us'd singly or combin'd, according to the fancy of the Builder, the make and situation of the Place, or the charges that any one will go to.

The Air may be made temperate in this sixth Construction, as well as in the others.

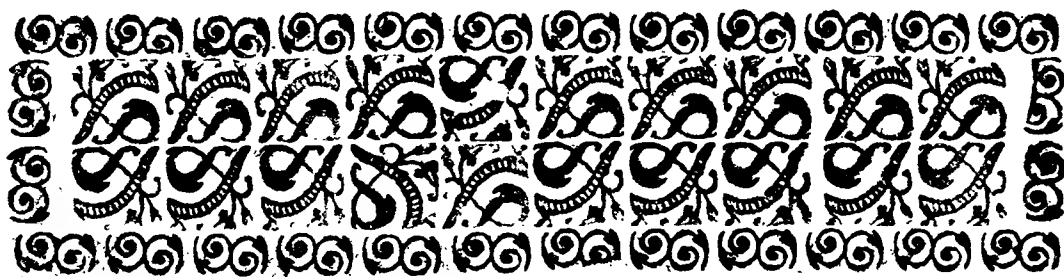

C H A P. VIII.

Seventh Construction for Chimneys in great Halls, or places to warm several People at once.

TH E Constructions given in the foregoing Chapters, are only for the Chimneys of common Chambers, or of Closets; but for great Halls, and Fire-Places for Colleges, or other publick Societies, we must vary a little from the proportions before laid down. In the great Chimneys of such large Places, the Wood is burn'd whole, especially where the Billets or Pieces are but 3 foot and 8 inches long, that they may go in quite to the Back of the Chimney, without being cut shorter: In order to make the Model *AHC cha* [Fig. 12.] you must first make *Cc*, the distance of the sides at the back of the Chimney, 5 Foot 8 Inches, and the Line *Aa* 7 Foot, or something less; we suppose it here of such a length, as is fit to determine the opening of the forepart of the

the

the Chimney, and the length of the Mantle-Tree; the Line AB and ab is 2 foot long, being the measure of the depth of the Chimney, and $CGcg$ each of 5 Inches; the Lines $AGag$ must be drawn, and $G.H, gh$, must be 7 Inches each; joyn the two Points C and H by part of a Circle, whose Center and Radius is found in the manner taught in the first Chapter, and you will have *cha* the stroke or line of the Model for those great Chimneys; or else if you wou'd be so exact, you may make the sides parabolical. The most simple Constructions are always sufficient for these great Chimneys, because the Cavity at the Back being higher and longer than in common Chimneys, it will contain a great quantity of Air, of which only a small part will go out each instant; therefore there will always remain a greatdeal of warm Air, which will also warm the fresh Air that is constantly coming in; besides, the Fire taking up more room, will consequently give greater Heat to the Air in the Cavities, which must be made about 5 Inches deep, and the passage where the Air comes in, passes thro', and goes out, must contain about 80 square Inches.

When these Chimneys are built for great Societies, you may, if the Place will allow it, have them in the middle of the Room, setting

setting two of them back to back, so that there may be Fire on both sides. The same Cavity may serve behind, being divided into Cells; so that a Fire may be in either Chimney, and produce the same Effect; and when it is in both, it will warm the Room faster, because it gives the Air much more Heat. If there be two distinct Rooms in common Apartments, whose Chimneys are back to back; instead of the usual Back, an Arch may be so built, as to have one Cavity common to both, so as to give Heat to either Room, or to both at once, as you shall see fit.

C H A P. IX.

How to make the Air which comes into the Room Temperate, in what degree of Heat or Cold you please. [Fig. 21. & 24.]

IF you wou'd have the Air that comes into the Holes R or r to be sometimes hot, sometimes cold, and sometimes temperate, by having both come in together, and by that means encrease or diminish the Heat of a Room, without encreasing or diminishing the Fire; near the Hole R or r, where the hot Air comes into the Room, there

there must be a communication with the passage *y*, from whence the External Air comes immediately in, before it goes into the Cavities; and contrive the matter so, that what opens the passage for hot Air to go into the Room, may shut out the cold Air, and so reciprocally; or else sometimes open one, sometimes the other Hole, or what part you will of either. This may be done several ways; here follows the description of some easy and simple Contrivances for that purpose.

[*Fig. 14, 15, 20, 24.*] Get two hollow Cylinders, like two round Boxes or Barrels, to turn one within another, the biggest being about a Foot Diameter, and 9 Inches high; make three openings in it, *viz. gl, mn, dp*, each 5 Inches wide, and 8 Inches high; the space *lm*, which is 6 Inches wide, must be left full, as well as *nd* of 2 Inches, and the remaining part *pg*: In the least or inner Barrel leave *qc* open 6 Inches wide, *bc* and *qy* full, being of 6 Inches each; let the remaining part *yb* be open, and 8 Inches high; between *n* and *d* leave a small part butting forward into the opening *qc*, that as the little Cylinder turns about, it may stop when the Points *q* or *c* strike against it.

To fix this double Cylinder, place the opening *nm* to the way of the warm Air from
the

the Cavities; let pa be open into the passage for the cold Air, and gl open towards the Chamber, as may be seen in the 20th. 21st. and 24th. Figures; now when yq is over against pd , only the warm Air, or that which has pass'd thro the Cavities of the Chimney, will go into the Room; but if you turn c over against n , nothing but cold Air, or such Air as comes immediately from without Doors, will come into the Room; for the Hole mn thro' which the warm Air came will be stopp'd; but if the Point c was only brought forward to the middle of the Hole mn , half of pd wou'd be open, then warm and cold Air wou'd go into the Cylinder, which wou'd be mix'd as they came out thro' the Hole gl ; if you shut up but a third part of nm , you thereby only open a third part of pd , &c.

[*Fig. 15, 21, 24.*] That you may turn the inner Cylinder easily, at the end o of its Axis, you must fix a kind of an Hand go that may come out in some part of the Chimney-Piece, or any where else in the Room, where you must draw an Arc that shews how far it must turn to open or shut the Holes of the Cylinders, and divide this Arc into degrees, that as you turn the Hand, you may know whether the passage is open for the cold or for the warm Air, or for both, and
in

in what proportion you let them mix as they come into the Room.

[*Fig. 14, 15.*] If you left full only the space cb of the little Cylinder equal to dm or np , you might successively shut up the three Holes of the great Cylinder, or leave them all three open, or leave only as much of pd open as you have of nm shut.

[*Fig. 16.*] You might even take off part of those two Cylinders, and leave only $pdnm$, of the great one, and cb of the little one, as you see in the 16th figure; then you will not have occasion for so much room for this Machine, which is as exact, and much simpler than the other.

[*Fig. 17. 18.*] Joyn at right Angles, or square to one another, two little Frames pd, nm ; the breadth of each of the Holes pd, nm must be of five Inches; and the height which is represented in *fig. 18.* of 8 Inches; within the right Angle, at the Angular Point fix a Shutter cb , which may alternately shut the Frames, which must be so plac'd, that one of the Holes may answer to the passage of the Air from the Cavities, and the other to the place where the External Air comes in immediately, as may be seen in the 20th. figure; instead of a Hinge you must have an Axis for the Shutter to play upon, with a Hand fix'd to this Axis, by
which

which you may move the Shutter ; or if by reason of the distance from the Axis to the place where you can come to move the Hand, too great a space wou'd be described by the end of it, which describes a quarter of a Circle ; you may do it with a Wheel on a Pinion made in what proportion you please, to know at sight in what manner the Holes are open, and have an Index which takes up but little room.

You may have two Shuts if you will, made in such manner as to shut up, or open both Holes ; or by fixing them at right Angles, to have one Hole open, when the other is shut ; and then loosen them from each other, to make them single Shuts as before.

If both Holes were in the same Plane, one Frame with a Board sliding in a Groove wou'd do.

C H A P. X.

Of the Vent-Hole or Bellows. [Fig. 13, 21, 24.]

TH E Vent-Hole, whose uses we have explain'd in the foregoing Books, is as convenient, as it is simple. To a little Frame of Copper or Plate-Iron, whose inside is about 3 Inches long, and $2\frac{1}{2}$ Inches wide, or to such an Hole made in the Hearth-
L Plate

Plate when there is one, fix with a Hinge a little Trap Door Z, so that it may shut close; and instead of rabbiting the Frame and Trap-Door, let both be bezell'd or sloap'd, that no Ashes may lie on the edge of the Frame, which wou'd hinder it from shutting close: on that side which is opposite to the Hinge, have a little Button that you may lift up with the Tongs; and if you will, the Button may have a Bolt fix'd to the under side of it, to open when you turn the Button; at the under side of this Trap-Door, on each side have a small portion of a Circle, or a Sector, whose Center is at that part of the Trap-Door where the Hinge is, that when you lift it up, the Wind may only blow directly upon the Fire; and that the Trap-Door may stand open at such an height as you think fit, fix a couple of Springs under the Frame, each of which must bear against the Limbs of the Sector-Pieces, and so keep the Trap-Door fast at any opening: This Trap-Door is represented under the 17th fig. When the Hearth is not cover'd with a Plate, Hooks or Staples must be fix'd to the Frame, in order to fasten and seal it close over the Hole made about 12 or 15 Inches forwarder than the back of the Chimney for that purpose, and into which the External Air comes in at a little Canal, as *h z.*

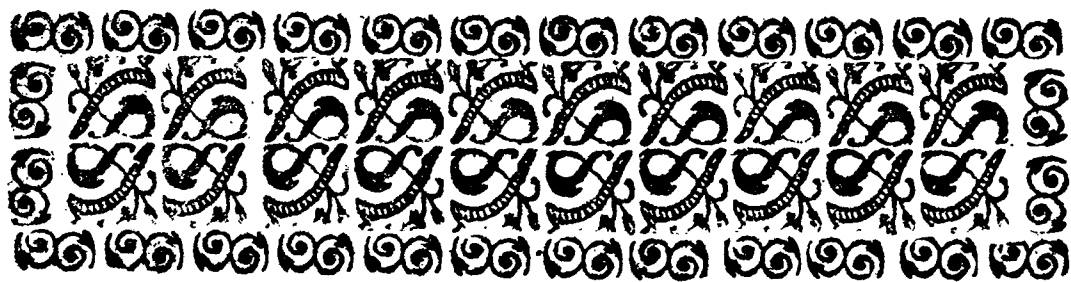

P A R T. II.

This Part directs how to order the upper Part of the Funnel of the Chimneys, to hinder the Smoke, to increase the Heat, and to be able to put out the Fire in the Funnel.

As we have in the second Book mention'd the Contrivances at top of the Chimneys, we shall here fully describe them. And in order to apply them more easily, care must be taken in such Chimneys as are built New, to carry the tops of their Funnels, so as to have their sides touch in a Stack of Chimneys, that it may rather make a Parallelogram than a Square at top: When there is occasion for the second Construction, it will readily be fix'd to such Chimneys. If we wou'd do without it, we must take care that the Chimneys be built so as not to be commanded.

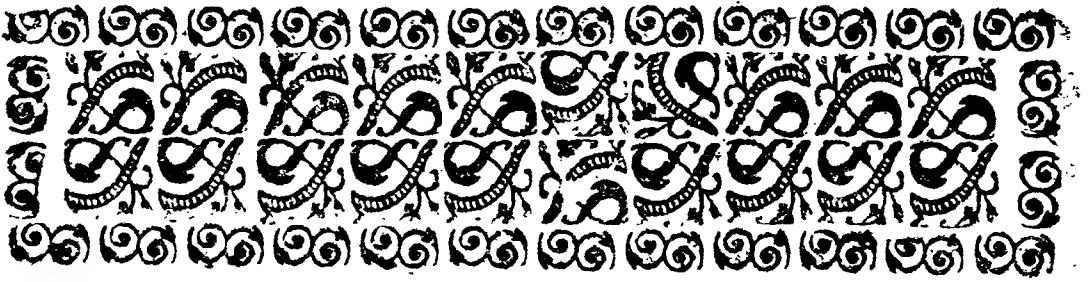

C H A P. I.

Of the first Construction apply'd outwardly to the top of the Funnel.

TH E first Construction may perhaps not appear new, because several Chimneys have something like it; but since it is not universal, nor made in that just proportion as it ought to have, and especially because it is part of the second Construction, we must give it here.

[*Fig. 8.*] Then supposing *Aa* the length of the Hole at top of the Funnel to be 30 Inches in the clear, that is, on the inside; and its breadth *AB* 10 Inches; shut in two Inches of it round about, in such manner, that it may open sloping within the Funnel, and thus your Hole will be but 26 Inches long, and 6 wide; divide that length in *CD*; *cd*, by two Partitions of 4 Inches each, whose underside must end in an Angle within the Funnel, and there will be left three Holes, each 6 Inches square.

Make

Make three truncated Pyramids, square and hollow, whose Bases in the inside must be 11 or 12 Inches square, and the top 5 or 6; you must divide each of the Holes at top into two, by a Partition 2, or, 3 Inches deep; but every Hole must not be divided the same way, the prickt Lines in the Pyramids A E G D, D I M D, *dega* whose height is 12 or 13 Inches; lay and fix these three Pyramids near one another, over the Holes A B C D, D C c d, *dcb a* of the Funnel of the Chimney, in such manner, that the Letters of the Bases may answer to the same Letters at the top of the Funnel, the Line B A in the one, lying on the Line B A in the other, &c. This will be sufficient for most Chimneys; but when it happens not to have the desir'd Effect, you must make use of the second Construction, or rather finish the second Construction, of which this is but part.

If the Hole of the Chimney is less then we suppose, diminish the Holes of the Pyramids; and if it be bigger, increase them, or instead of three, make use of four.

These Pyramids may be made of Plaister or Potter's Clay, baked like Earthen-Ware; or else you may make use of ~~fire~~, especially when you wou'd make use of the Capital, which we shall describe in the next Chapter.

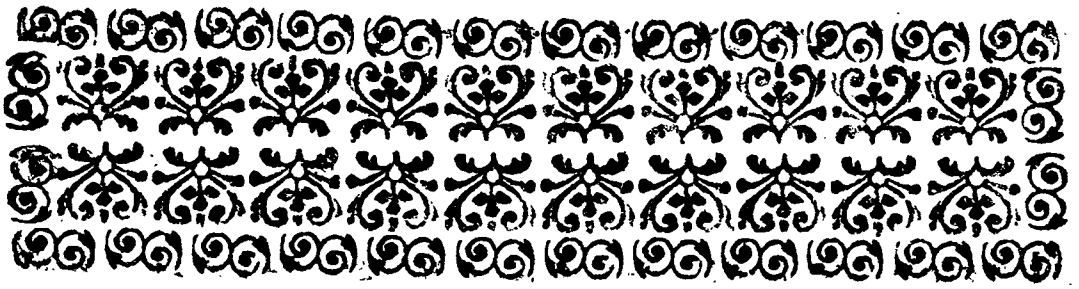

C H A P. II.

Of the second Construction of the top of the Funnel of Chimneys.

[Fig. 33.] **T**H E Pyramids being made and fix'd after the manner that we have mention'd, add the Capital whose particular Pieces are as follows.

[Fig. 10.] The first and second Piece are two Boards A H L M O B; *ahlmob*; (all the Lines mark'd in these two Pieces with the same Letters will be equal, and so it is enough to determine them in the one; or indeed when you have drawn and cut one, you may easily cut the other by it, by laying the first on to scribe it;) the breadth of A B at bottom must be about 13 or 14 Inches as well as G B; the height A G or B P, 8 Inches; G H or P O, 6 Inches, as well as H I and O N; the breadths H O and I N, 12 Inches; I L and N M, 8 Inches each, and L M, 5 : Q R S is a Triangle where the Wood must be cut out; its Basis Q S in the same line as I N is 6 Inches;

6 Inches; and the two sides QR, RS, 7 Inches each; A FEB shews the place which must answer over against the Face A EFB of the Pyramid A EGD, when the Pieces [Fig. 8.] of the Capital are put together and fix'd upon the Chimney.

[Fig. 10.] The third Piece SRQ *grs* must be a Plate of Tin 30 Inches long and 14 broad, which you must fold in the middle along the prick'd Line Rr, to make a sort of a Gutter, or a triangular Prism, if you cover the upper part of it.

The fourth Piece GLlg, and the fifth Piece FMmp, must be two other Plates of Tin, each 32 Inches long, and 20 broad, indented along their length, as you may see in the Figures, in such manner that LT, UX, YZ, &c. shall be 5 Inches each, and the lines TI, IU, &c. 7 Inches each; the prick'd Lines Hh, Ii, Oo, Nn, mark the places where these pieces must be folded, when you nail them upon the two first; they are made of Tin as well as the third, rather than of thin Plate-Iron that is only black, because the Rain will cause such a rust as will quickly eat thro' it.

To join all these pieces together, set up perpendicularly the first pieces one over against another; and at 30 Inches distance one from another, that is at a distance equal
to

to the length of the hole of the Chimney; in these two Pieces fix the third by its ends, which you must thrust into the Triangular Holes QRS, qrs , folding it as far as the Hole requires; then you may join also to 'em the fourth and fifth Pieces, folding them as much as is necessary to have their ends $GHIL, ghil$, $PONM, ponm$, rest upon the edges of the two first, beginning from GP, gp , [*Fig. 8, 9.*]

All these Pieces being thus joyned together, you must fix them above the three Pyramids, in such manner, that the line Rr of the Piece which is a Triangular Prism, may lie over the middle of the upper Hole of the three Pyramids, which need not be divided here: The ends AB, ab , of the two first Pieces, are to rest upon the two sides AB, ab , of the Funnel of the Chimney; fasten and seal the Hole very well when it is in this situation, and you will have the second Construction.

If you wou'd not make the two first Pieces of Wood, for fear of Fire or wearing out too soon, make only the Model of Wood, that by means of it, you may on each side raise a Wing of Plaister upon AB, ab , and so fix and seal, on the sides and in the middle, the third, fourth and fifth Pieces, in the manner

ner that we directed to fix them to the Wood.

If you had rather make the Hole of Tin, as well as the truncated Pyramids, you may carry the whole Machine ready fitted to the top of the Chimney, where you may fix it without any trouble, and be sure that it is tight.

C H A P. III.

Of the Construction of the inside of the Funnel of Chimneys, in order to put out the Fire that might catch there, to keep in the Heat in a Room all Night long, and to hinder the Smoke of a Neighbouring Chimney from coming in; and also concerning the Instrument for covering the Fire.

TH E Register Plates for putting out the Fire in the Funnels of Chimneys, keeping the Room warm all Night, and hindering the Smoke of a Neighbouring Chimney from coming into yours, which often happens when your own Fire's out; and the Cover-Fire Instruments, are of such common use, that what we have of them in the *First Book* might suffice; but that we may not be wanting

wanting in our Directions to the Workmen, we will here describe 'em more particularly.

[Fig. 5, & 7, 25.] Two thin Plates of Iron *STts*, [Fig. 5, 25.] *NOon*, fig. 7. exactly as long and as broad as the hole of the Funnel of the Chimney is where you design to have 'em, are sufficient for the inside of the Chimney.

The first Plate *STts* must have in the middle of its breadth a small Axis *pP*, whose two ends *Pp* must stand out about an Inch or two; and there must be two Wires *UM*, *um* fix'd to the middle of those two ends *Uu*, that you may keep it in what situation you think fit.

[Fig. 7.] The second Plate *NOon* must have its Axis *NO*, or *Nn* at its ends *Nn* or *NO*, and a stiff Iron Wire *IH* fix'd to the middle *I*, to put it up or down as you see fit.

[Fig. 5, or 25.] To fix the first Register Plate, in two opposite Places of the Funnel within two foot of its Hole at top, make two Holes *Pp* [Fig. 4.] over against one another; in the middle of the breadth of the fore and back part, put in two Iron Eyes for the ends of the Axis to play in, and make two Ledges in the Chimney, in such manner, that the Plate may go no further when it shuts close; bring ~~down~~ the Wires *UM* *um* down
the

the Funnel into the Chamber, where they must be fasten'd that you may easily come at 'em, to open or shut the Register Plate.

Instead of little Ledges in the Funnel to keep the Register Plate tight, when it is brought down to a level position, you may make it a little longer than the Hole of the Chimney, and then it will be close shut, before it be brought quite down to an Horizontal position.

[*Fig. 7 & 26.*] To fix the second Register Plate *NO on*, you must also make two holes in the two corners of the lower part of the Funnel of the Chimney, to let in the two ends of the Axis *Nn*, or *N* and *O*, according to the easiest way of opening it; the best way being to have it play upon *N* and *O* let into the corners, that when it is open, it may be flat to the Chimney, where the stiff Wire or long Hook *HI* will keep it, by putting the end of the Hook, in an Eye at *H*.

As to the Fire-Cover, which may be of Copper, Brass, Plate-Iron or Tin, it is shap'd like a Box without a Cover, about 2 foot long, 10 Inches wide, and 6 deep, with a Loop to move it easily: If it be of Tin, the Plates must be rivetted as well as solder'd, or else the Fire wou'd soon make them fall from each other.

The

The two Register Plates being fitted within the Chimney, if the Chimney shou'd be on Fire, take the Coals out of the Hearth, and shut down the two Register Plates, as we have shewn, by pulling the Wire *Mu*, (*Fig. 4* and *8.*) of the upper Plate, which serves for that use; and the Hook *I H* (*fig. 26.*) of the lower Plate, and the Fire will go out immediately; it wou'd go out, tho' you shou'd shut down but one of the Register Plates, but not so soon; and then you wou'd be troubl'd with the Smoke till the Fire was quite out, tho' you might to avoid that, throw Water upon the Fire in the Hearth, whose Vapour wou'd help to quench the Fire in the Funnel, and shut up the forepart of the Chimney with a wet Cloath, or any thing else; But if you have two Register Plates, the best way is to shut them both down.

By shutting down the upper Register Plate, you will keep out the Smoke of a Neighbouring Chimney, which is often blown down yours when you have no Fire; by this means you may keep the warmth in your Room all Night, but then take care either wholly to put out your Fire, or at least to have no smoking Coals.

If you rake up the Fire together on the Hearth, and put the Cover over it, so that

no Air comes under it, the Fire will soon be put out; but if you wou'd keep in the Fire all Night, cover the burning Coals with the Ashes, and put what Wood is left unburn'd over them, and lay on the Cover so that a little Air may go under it, then the Fire will be kept in without consuming much: In such a Case, the best way is to let down neither of the Register Plates, but to cover the forepart of the Chimney to keep out the cold Air, and keep in the warm.

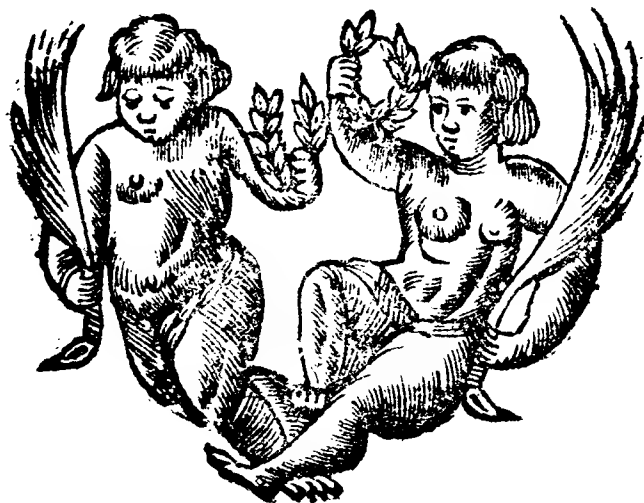

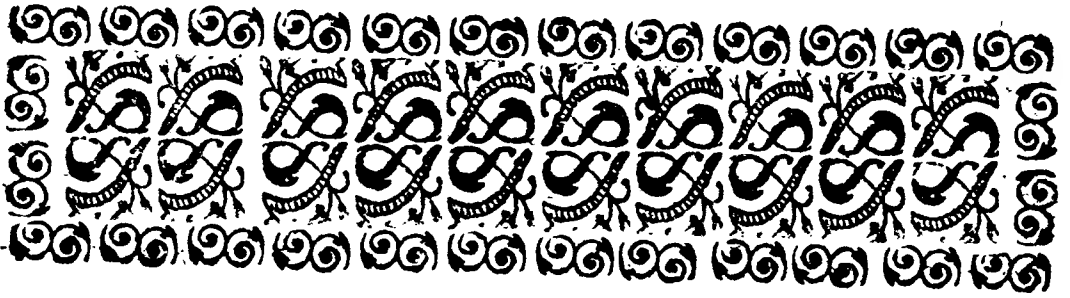

P A R T III.

Of the Effects and Advantages of the new Chimneys, and how to make use of them.

It is not enough for the Workmen to be able to make all the abovemention'd Works, unless they also know the use of them, which will be a means to make them the more perfect, and to enable them to give an account of their advantages to those Gentlemen which they make them for. This is the reason why we add this *Third Part*, in which we must be oblig'd to repeat something of what we said in the two *First Books*.

C H A P. I.

Of the Effects and Properties of these Chimneys.

BY means of our new Chimneys you may,
 1st. Kindle a Fire very soon; see it
 always

always flame, without being obliged to blow it; and without confining your self to the use of small Wood, make use of the biggest Billets, and even green Wood. See the *4th. Chap. of Book 1. Part 1.*

2dly. Warm a great Room with a little Fire in a little time, and sometimes the next Room to it. *Chap. 2. and 3. Book 1 Part 2.*

3dly. Encrease or diminish the Heat of a Room, without encreasing or diminishing the Fire. *Chap. 3. Book 1. Part 2.*

4thly. Warm your self on all sides at once, without burning your Legs, Eyes or Face; and so avoiding all the Inconveniencies that attend very cold Weather. *See the same Chapter.*

5thly. Hinder the cold Air from coming in under Doors or thro' Crannies; and make that little which may come in, be thoroughly warm before it comes to you, if you are at ever so small a distance from the Windows or Doors where it comes in. *The same Chapter.*

6thly. Bring warm Air upon your self at any distance from the Fire, without being oblig'd to go near it. *The same Chapter.*

7thly. Warm your Bed even whilst you are in it, without any danger of burning you; and cause warm Air to be blown up-

on any Part, so as to keep it warm. *The same Chapter.*

8thly. Constantly breath fresh Air, of what degree of Heat you please; so as not to dry or offend your Lungs. *The same Chapter.*

9thly. Drive all the Air out of a Room in a little time, and cause it to be succeeded by new Air heated to any degree in the coldest Season, and dried in the moistest; and thereby prevent the inconveniences and unwholsomness of stagnating and vitiated Air, such as is commonly in a Room where any Body is Sick. *The same Chap. and Chap. 4.*

10thly. Have your Room so dry, that your Goods will not be damag'd, during the greatest Fogs, or when it thaws ever so fast. *The same Chap.*

11thly. Keep a Room warm all Night, tho' the Fire is put out. *Chap. 1, 2, 3. Book 2. Part 3.*

12thly. Never be troubled with Smoke, which offends the Eyes, causes Distempers, and spoils your Linnen, &c. *Book 2.*

13thly. By your self, and in an instant, put out the Fire that may chance to catch in the Funnel of your Chimney. *Chap. 2. Book 1. Part. 3.*

14thly. Hinder the Smoke of a Neighbouring Chimney from blowing down into yours. *Same Chap.* And

And Lastly, make several Chymical Operations.

C H A P. II.

How to make use of the new Chimneys.

[*Fig. 6, & 24.*] **T**O kindle the Fire in these Chimneys, take a lighted Charcoal, or a piece of Paper, and setting it between two or three sticks, open the Bellows, and all the Wood will quickly be on Fire.

As the Bellows or Vent-Hole blows so much the stronger, as there comes less Air into the Room otherwise; when the Wind does not blow, or the Weather is not very cold, you may shut up the other passages where the Air comes in; that is, if the Room does not smoke, otherwise it would be better to leave them open, and wait a little longer for the burning of the Fire.

[*Fig. 6, 21, 24.*] When the Weather is very cold, the Wind comes always violently into the Hole R, which opens into the Room; so that before the Cavities of the Chimney be warm'd, it comes in very cold; therefore you must shut up R at first, unless by so doing, the Room should smoke: And in that

case you must take care to make the Flame strike against the Back, so as to warm the Plate in the second, third and fourth Constructions, and likewise to cause it to pass underneath, and so behind in the fifth, that the Air in the Cavities may be soon warm'd; and to hasten this, you might shut up part of the Hole D, thro' which the External Air comes into the Cavities; for the less of it comes in, the faster it will be heated; but you must always let in enough to hinder the Smoke: And if the Room did not smoke (as it will happen to most Chimneys, especially at certain Seasons) tho' the hole for the External Air should be wholly shut, it wou'd be well to leave it so for a while, till the Cavities behind the Back were heated. After any one has made use of these Chimneys a little while, Experience will teach the management of them much better, than all the Instructions I can give.

When you find the Room warm enough, and you wou'd not have the Heat encrease any more, tho' you are unwilling to lessen your Fire; you must shut up the Hole R, [*Fig. 6, 21, 24.*] where the warm Air comes in; and if you wou'd have the Heat diminish, open *pd* the entrance for cold Air, and shut *nm*; if you wou'd give the Air that comes in, different degrees of Heat or Cold, leave part
of

of each passage open, more or less as you see fit.

When you put out the Fire at Night, or in the Day-time, always take care (especially when the Weather is very cold) to shut up D where the External Air comes in, for otherwise the Room wou'd quickly be cold ; nay it will be proper during the whole Night to let the forepart of the Chimney be wholly shut up ; or if the Coals smoke no more, it will be enough to shut down one of the Register Plates, if you have any, that no cold Air may come in that way, whilst the hot Air goes out.

Now as the Hole R where the External Air comes in after it has acquir'd Heat in the Cavities, must be big enough to supply as much Air as will hinder the Room from smoking ; you may shut all the other Places where Air might come into the Room, as well about the Doors as the Windows ; and that as small a quantity as may be, may go in when the Door is open'd or shut, it will be proper to have a double Door, one of which must be always shut before you open the other ; but this is only necessary in very severe Winters, tho' it is always useful.

If you cannot have a Vent-Hole, or will not always make use of it to light your Fire ; you must have a pair of Bellows that blow constantly,

stantly; whose Description I shall not give from the French Author; because they are become pretty common, and may be had at several Bel-lows-makers, being made according to Captain Savery's method, which is better than the French Author's way, and for which he had a Patent.

The Conclusion of the whole.

If this Book by rendering the use of these Chimneys common, makes ingenious Men leave their sublime and merely curious Speculations, and apply themselves more to simple Mechanics for the general good of the Common-wealth, I shall have my End.

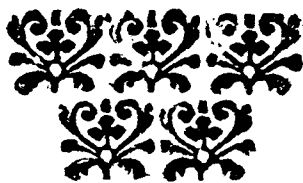

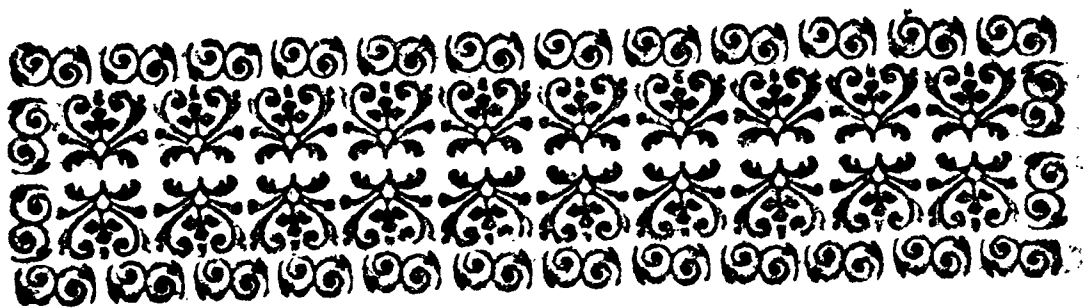

The Explanation of the Figures.



H E Figures 1, 2, 5, 7, 12, 13, 14, 15, 16, 17, 18. need no other Explanation, then what is given in the Chapters, where they are referr'd to.

The *Third Fig.* represents the Profil of a Chimney, cut by a Plane perpendicular to the Hearth and to the Back.

Z, is the Trap-Door of the Vent-Hole or Bellows; and *x* its opening when it blows.

F, the Place where the Fire is.

Tt, the Ash-Hole, and below it the Cavity under the Hearth.

SGA, the Cavity behind the Back of the Chimney.

oim, the Horizontal Plane under the Mantle-Tree, as we wou'd have it.

I, the Cavity or Passage under the Mantle-Tree.

mLNR,

mLNR, The Funnel of the Chimney.

oR, the Line which denotes the slope of the Breast, where the space *omR* is wholly void, as in common Chimneys.

The upper part of the *Fourth Fig.* is the Profil of the Funnel of the Chimney, with the Pyramids and Capital above them, and the Register Plate within; the Section being made by a Plane passing thro' the Axis of the Prism *Rr*.

The *Sixth Fig.* represents a Chimney quite finish'd, whose Sides or Jams are parabolical.

AHCchaA, is the Hearth.

Z, the Vent-Hole with its Frame.

KTkt, the Ash-Hole.

ODFIL, the Back with the thick strong Plate fram'd in before the thin Plate, to hinder the Wood from burning the thin Plate, when there is a Cavity behind the Back for the passing of Air.

Dd, the Door for the Air to go into the Cavities.

Rr, the Doors of the Holes where it must come out again.

gb, the little Hand to turn the Cylinder or Shutter, which opens or shuts the Air's Passage.

P, a Paper hanging by a Thread before the Hole *r*.

The *Eighth Fig.* represents the upper part of the Funnel of the Chimney, with its three Pyramids above, whose lower Parts we have left uncover'd, to shew the Holes of the Funnel.

TtsS, in the Register Plate which must be fix'd so as to play in the place where it is drawn, in order to put out the Fire that might catch in the Funnel; *Pp*, are the Pivots upon which it turns; *VM, vm*, part of the Wires which serve to open and shut it; it is here represented shut, but the prick'd Lines represent it open'd. The forepart of the Funnel has been left open, to shew this Plate.

The *Ninth Fig.* is the Capital, which it is sometimes needful to fix above the three Pyramids; it must be so fix'd as to rest upon the upper part of the Funnel of the Chimney, *AB* of the Capital lying upon *AB* of the Funnel, and *ab* upon *ab*, the Surface *HGgh* covering part of the Pyramids, and the Line *Rr*, resting on the top of the Holes of the Pyramids.

The *Tenth Fig.* shews all the Pieces of the Capital by themselves.

The *Eleventh Fig.* is a Profil of the upper part of the Funnel, of the Pyramids, and of the Capital; all cut by a Plane perpendicular

dicular to the the thikness of the Funnel, or to the Axis of the Prism S Q R.

E p, in the Funnel are the Holes where the Centers or Ends of the the Axis of the Register-Plate must play.

A F F B, is one of the Pyramids.

Q R S, the Section of the Prism above them.

G H I L M N O P, the Section of the Capital which covers them.

In this Profil you may see how easily the Smoke can come out of the Chimney, and how hard it is for the Wind to blow down into it.

The *Nineteenth Fig.* is the Geometrical Plane of the fourth Construction of the Chimney, which is represented by the *Twenty-fourth Fig.*

A H C *cha*, is the Hearth.

Z, the Cavity under the Vent-Hole or Bellows.

H Z, the Canal or Passage for the Air to come into it.

K T *kt*, the Ash-Hole.

H M, C N *cn*, *hm*, the lower end of the Partition Plates, which part the Cavities.

H M C N, C N *nc*, *ncmb*, the Bases of the three Cavities behind the Sides and Back of the Chimney.

D y, the

Dy, the Channel for the Air to come into the first Cavity.

The *Twentieth Fig.* is an Horizontal Section of the same Chimney, immediately under the Mantle-Tree.

Bb, is the lower edge of the Mantle-Tree.

BEeb, the lower part of the Passage under the Mantle-Tree.

EXxe, the hole of the Funnel of the Chimney.

dpl, the Passage for the Air to get up under the Mantle-Tree.

dpi, the Passage for the Air to come down from it.

XOox, the upper part of the Cavity where it comes up behind the Back.

XOm, xom, the lower part of the Ways of it into the Room.

mnlg, the Basis of the Cylinders thro' which the Air comes in.

mpu, the Square with the Shutter, which serves for the same purpose on the other side.

XO, xo, the upper part of the Partition-Plates.

If you suppose this Plan over the former, (*viz.* the *19th. fig.*) you will have the Chimney as it is, and as you see it in the *24th. Figure.*

The *Twenty-first Fig.* shews the fifth Construction of a Chimney, with the forepart of the Back taken off from H to *b*, as also the middle part of the Mantle-Tree and the bottom of the Breast, to shew all the back part of the Chimney within, or the inside of the Box of cast Iron, where the Air passes winding as the double Lines shew.

AHC*cha*, is the Hearth.

Z, the Vent-Hole with its Frame.

HZ, the Passage for the Air to come to it.

Z*ahp*, the Passage to carry the Air up to the Cylinder.

CG*g*, FE*e*, H*bL*, *xmM*, the Partition Plates fix'd to the back part of the Box.

The Line CT*tc*, shews the height that the Box must be plac'd above the Hearth, and N*ln* the prick'd Line beyond, shews the Space that must be between the Back of the Box and the Back of the Chimney; but you may see it better express'd in the *26th. Fig.*

vvv, the Holes where the Air and Heat go out from behind the Box.

glmn, is the Cylinder thro' which the Air goes into the Room, which may be placed on the other side, as well as where it is represented, as it suits best with other conveniences.

The winding Lines in the *Twenty-second* and *Twenty-third Figures*, shew the way of the
the

the Air in different Constructions of Chimneys.

The *Twenty-fourth Fig.* represents the *4th.* Construction of a Chimney, the Plate of the Back being taken off from *HI*, to *hi*, to shew the Partition-Plates, and the Passage which they make behind the Plate and the way of the Air represented by the white Lines. The Mantle-Tree is also taken off from *B* to *b*, and the Canal or Passage behind it from *EL* to *el*, to shew the inside behind the Back and the Way of the Air from without Doors, round thro' all the Cavities into the Room.

AHCgha, is the Hearth hollow underneath.

Z, the Vent-Hole or Bellows.

KTtk, the Ash-Hole.

ABIH, *abih*, part of each side.

HIXC, *CXxc*, *cxih*, the three Cavities of the Bottom and Sides laid open.

XONC, *xonc*, the two Partition Plates which divide the Cavity into three Cells.

BESL, *besl*, the two Sections of the Passage under the Mantle-Tree.

lmng, the upper part of the Cylinders.

mn, the Hole where the warm Air comes in; *pd*, that where the cold Air comes in; and *gl* is the passage of the Air into the Room thro' *R*.

D, the Hole thro' which the Air goes into the first Cavity.

The Arrows shew where the Air goes upwards, or downwards, or horizontally; so that which is above I, shews that the Air in that place goes out of the first Cavity into the Mantle-Tree Canal, to go towards the other end of it *i*, where the other little Arrow shews that it goes in again in that place to come out between *g* and *q*, and go down the Cavity *ixc*, as the Arrow there points; and then under the Hearth, whence it comes up the middle Cavity, and at last goes quite out to the right Hand or to the left, or both ways at once.

The *Twenty-sixth Fig.* is the Profil of the *5th*. Construction of a Chimney, cut by a Plane perpependicular to the Hearth and Back.

Z, the Bllows, *x* its opening.

KT, the Ash-Hole.

LTV, the thickness of the Box, behind which you may know what space ought to be left.

IC the Register Plate at the entrance of the Funnel, and HI, its Hook which keeps it up.

oim, the horizontal Plane under the Mantle-Tree.

The *Twenty-seventh Fig.* represents the cast Iron Box, for the *5th.* Construction, the fore part being taken off, to shew the Cavities and Partitions.

The *Twenty-eighth Fig.* shews all the Pieces of the Box.

The *Twenty-ninth Fig.* is the Geometrical Plan of the *5th.* Construction.

AHC*cha*, is the Hearth which is not hollow underneath.

Z, the Bellows.

HZ, the Passage for the Air to it.

CN*nc*, the Hollow to place the Case in. The distance between N*n* and the pric'kd Line, shews the Space that must be left behind the Case when it is laid.

HPNC, *hpnc*, are the Bases of the two last Cells when there are five.



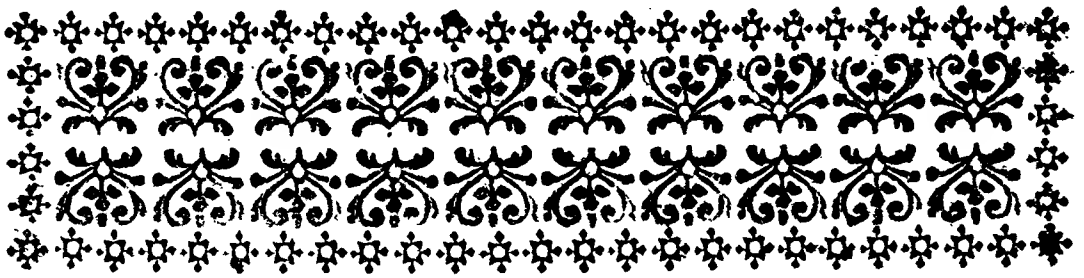

The TRANSLATOR'S Additions.

First, **T**HE French Author having directed us to use Plates of Iron, Brass or Copper, to line the Chimneys, and make the Cavities behind them; I had a mind to know whether the External Air which warm'd it self in rushing thro' those heated Cavities, did not bring along with it unwholesome Particles of the Metal into the Room: For that Reason I got three Cubes of the three different Metals, one of Iron, another of Copper, and another of Brass, each of them weighing 5 pound. I drill'd an Hole into the middle of each of them, about an Inch and an half deep, and $\frac{1}{4}$ of an Inch in diameter, as is represented by *bo*: (*Plat. 4. fig. 30.*) Then having exhausted the Glass Receiver of an Air-Pump of its Air, I took the Iron Cube (which had been heated by blowing under it in a Charcoal Fire, so as to look almost white,) and setting it upon a Brick *Bb*, I thrust the end

end *b* of the Pipe that came from the top of the Receiver *R* into the Hole *bo*, then turning the Cock *C* which opens into the Receiver thro' the Brass Plate *Pp* that covers it; all the Air which came into the exhausted Receiver to fill it again, ran first into the Hole *b* by the sides of the Pipe *CT* *b*, till it got to *o*, where coming into the Pipe, it went along *bTC* into the Receiver, carrying along with it the steams of the Iron, till the whole Receiver was fill'd with this burn'd Air. Immediately I lifted up the Plate *Pp*, and putting a Bird into the Receiver, I shut it up again, and the Bird liv'd there half an Hour, without the least sign of being Sick: Then making the same Experiment with the Copper Cube, a Bird was likewise unhurt in Air burn'd by that means, and impregnated with the steams of the Copper. But when I heated the Brass Cube till its Corners began to melt, and made the same Experiment with it; the Bird began to have Convulsions in half a Minute, and in half a Minute more died.

N. B. The Pipe was of Brass, only the end of it from *T* to *b* was of Iron, lest the Heat of the Cube should melt it. *Aa* is the Plate of the Air-Pump upon which the Receiver stood. The Birds were Linnets, but the same Bird was not put in twice.

I made the Experiment a second time with the Brass Cube, without having blown under it, only letting it to have a degree of Heat equal to the common Heat of the Fire; and in that case the Bird seem'd no way affected with the steam of the Brass. The reason of this difference I take to be, that there is a great degree of Heat requir'd to cause a separation of the parts of the *Lapis Calaminaris*, which enters into the Composition of the Brass.

From the consideration of those Experiments, it appears adviseable not to make the Back-Plate, or line the Cavities of the Chimney that are most heated, with Plate-Brass; tho' we may safely use Iron or Copper. If we wou'd use Brass, we may line the Jams or Sides with it, or such places as are not very much heated.

Secondly, When the Author gives direction about the curing of the smoaking Chimneys, he mentions the *North Wind* as blowing down Chimneys; but what he says is only for *Paris*, and such Places that have the Sea on the North side. Such Eddy-Winds (as they are call'd) blow from the *South* when we have them here at *London*; and generally speaking, in all Places we may expect that Wind to blow down the Chimneys, which comes from the Sea; I mean
when

when Chimneys are not commanded; for in such a Case there may be Circumstances that will make the Wind blowing from any Point to push down into a Chimney; but otherwise we must prepare against the Wind blowing from the nearest Sea.

The Construction of a Chimney in which you burn Turf or Peat.

IN Chimneys where you burn Wood, the Cavities behind the Back and Sides after the manner that the *French* Author directs, are very useful; but where you have your Heat very strong, but less diffus'd, it will be proper to make the Cavities as near the Fire as possible; and tho' the way of the Air wou'd be shorter, yet the greater Heat given to the Air in that Case, will make amends for the swiftness of its passage. This is what we have endeavour'd to do in this Construction of a Chimney to burn Turf; and in the next Construction for a Chimney to burn Coal.

[*Plate 9. Fig. 1, 2, 3.*] The shape of the Chimney and Model of it *KAY e f k*, are as in our Author; but here we have no Cavity under the Hearth, only we have a sort of divided Box of Plate Iron upon which the Fire lies, and an horizontal Cavity behind
the

the Back, fac'd with Plate Iron, so low that the Fire lies against it; and from thence the Air is carried up a Passage in the Brick-Work in one of the Corners as high as the Mantle-Tree: From the Corner it is brought forward in the Side quite to the Canal of Tin under the Mantle Tree, from which it is convey'd into the Room. The whole Mechanism of it will be easily understood by a sight of the Figures.

[*Fig. 1.*] Represents the horizontal Section of the Box or Cavities upon which the Fire lies.

DY is the entrance for the External Air in the 3 figures.

$\alpha Y E e B$ is the first Cavity whose height EA *fig. 2.* is equal to the Breadth αB of six Inches, and Depth $E\alpha$, 18 Inches; which is the common Depth of all the Cavities, five Inches of them going into the Wall as far as $EFGb$ beyond the Back.

BC is the Breadth of the second Cavity, *viz.* seven Inches, its Height CF (*fig. 2.*) being only 5 inches.

Cc is the third Cavity 4 inches high, and 9 broad. cb is the fourth like the second, and ba the fifth like the first: The Partition-Plates Be , F , fc , and G leave a space of 6 Inches from the Wall, or from the forepart of the Box as it appears in the Figure.

You

You see then that the Cavities are nearly equal every where to 36 square Inches.

Bb, is a Fender which is to be put on upon *Ab*, in such manner that the Pins under the Knobs may fall into the Rings *Bb*.

The double Lines represent the Way of the Air under the Cavities as far as *H*, where it goes up towards *b*, as you may see in,

[*Fig. 2.*] Which represents a fore-right view of the Cavities and Back.

EghID, is the horizontal Cavity in the Back, the bottom of which being of Plate Iron, rests upon *Ee* and *Gg* the first and last Cavity under the Fire, and the fore-part is also a Plate of Iron at *Fh g*.

This Canal is 7 Inches high, and 5 deep into the Back.

DEIKL, is the Canal in the Brick-Work that goes up from the last over *DIEY* of *fig. 1.*

LKMR, is the Section of the Passage brought forward in the Side from the top of the last Canal, into the Canal under the Mantle-Tree here represented by *MKNO*, and in no wise differing from that mention'd by the *French* Author. If you have not such a Canal, the Air may go out at *R*.

[*Fig. 3.*] represents the Section of this Chimney, by a Plane perpendicular to the Hearth and Back, where *DY* represents the Entrance

Entrance for the External Air, as it does in all the other Figures.

EAY, the first Cavity under the Fire.

DHI, the Section of the horizontal Canal in the Back.

HIKL, the Passage in the Brick-Work in the Corner or Angle, whose Section must be 36 Inches, whether it be square or oblong.

LKMN, the Passage in the Side from the Back to the Canal under the Mantle-Tree, whose Section here represented is NOM.

NR the way of the Air into the Room.

The double Line represents the Way of the Air where the Figure allows us directly to see it; and the single Lines winding, shew where Cavities face us endwise.

Tho' I have not represented the Bellows here, because some Peat don't need it; yet where a great deal of Air is requir'd to make Turf burn, as some sort of Turf won't burn without; then not only the Bellows is to us'd, but the Cavity *FfC* (*fig. 2.*) is to be sunk into the Hearth, its top *Ff* being carried down to *Cc*, and an Iron Grate fix'd in the Line *Ff*, thro' which the Ashes will fall upon the said Cavity and warm it. After the Fire is lighted and blown up, the Fen-
der

der (whose Height is 3 Inches) may be put in, and its upper part will be in the prick'd Line EcGg.

The Construction of a Chimney for Coal-Fires.

AS Coal is the common Fuel of *England*, I reckon this Construction will be the best lik'd and most us'd, especially since the Charge of it will scarce be double the price of a Stove-Grate. The whole matter is a Grate of a particular make, with a Box of Plate Iron behind the Back, that has only three Cavities, from which a Passage goes obliquely to the Corner in the Brick-Work, from whence it is brought forward in the upper part of the Side, quite into the Canal under the Mantle-Tree, as in the last Construction.

[*Fig. 4.*] Represents a Section of this Chimney, by a Plane perpendicular to the Back and Hearth.

DY, The Entrance of the External Air to go to the Bellows Z, by a Passage under the Hearth, and also for the Air to go up behind the Grate into the three Cavities, one of which is represented by QDHI.

HIL, Is the oblique Way to the Corner made in the Brick-Work, which is better represented by the same Letters in *fig. 5.*

O

LKMN,

LKMN, The Way from the last into the Canal under the Mantle-Tree, whence the Air goes into the Room thro' NR.

RsrS, The Grate made convex, that the Bellows Z may blow more fully upon it, the Wind from the rounded Cavity under Z being directed full against it.

sT, rt, Are the two Bars which come from each side of the Grate quite behind, to hold the Box of Plate Iron together, by means of another Bar Tt, which is fix'd to the two former by means of the Keys T,t.

The fifth *Fig.* represents the Grate seen from before the Chimney.

DY, The Entrance for the External Air.

Ddyc, A thin Plate of Iron 8 Inches broad and 9 high, fix'd to the Back of the Grate, and let down an Inch into the Hearth, as a means to bring the External Air into the first Cavity dEF, which goes into dDyc. This Plate is also represented in *fig. 10* tho' here it is suppos'd cover'd with Plaister of the thickness of the Back of the Grate.

HIih, Is another thin Plate 8 Inches square, likewise fix'd to the backside of the Back of the Grate in order to begin the Cavities HIL which may go deeper into the Back, than such Cavities as are cover'd with a Plate; Mortar being laid over the
Plate

Plate *Hlib* to make all tight. The same Plate is represented by *Fig. 11.*

KNML, The Section of the Passage along the upper part of the side from the Back to the Canal under the Mantle-Tree.

NMO, The Passage under the Mantle-Tree.

YZ, The Passage of Air to the Bellows.

Bb, The Fender, which is set upon the Trap-Door of the Bellows when you don't blow; but backwarder where the prick'd Line is, when you blow.

Cf, cD, The two Feet of the Grate which come directly from the Back of the Grate, and touch the Back of the Chimney.

Ps, pS, The two other Feet which are forwarder, as standing under the bended cross Bars *Rs, Sr*, Which hold the main Bars together.

Tet, fs QSD, The upper and lower main Bar, which as well as the others, are bent into an half Oval.

FdDSQs, A small Bottom-Grate for the Ashes to fall thro'.

The winding double Line, shews the way of the Air, and the single Line which takes two or three Turns shews the same in such Cavities as are seen end wise in all the Fi-

gures, which compared together explain one another.

Directions for the Workman in this Construction.

TAKE Plate of Iron 2 Foot long and 18 Inches broad and $\frac{1}{4}$ inch thick (*fig. 6.*) and cut off the upper Corners at F and I, so as to make it of the shape represented in the Figure. Then rivet to the backside of this thick Plate, the two thin Plates *Hih*, and *DdYy*, before describ'd; and you will have the first Piece.

The Partition Plates must be as thin as may be, six Inches broad, and fix'd edge-wise to the great Plate against the Lines *eFGHD*, and *EdfI*; they are seen edge-wise in *fig. 7.* so that if you imagine the sixth figure laid upon the seventh, you will have the second Piece.

DFGHe, (*fig 7.*) Is the first of these Partition Plates, which may also be seen in *fig. 8.* where the prick'd Lines represent the folding Places where the Plates must be bent into Angles equal to F, G, and H in *fig. 7.*

EdfI, (*fig. 7.*) Is the same as the *fig. 9.* where the Letters denote the Plate and its folding places, as before.

[*Fig. 12.*] Represents the whole Iron Box of Cavities seen from behind the Back of the Chimney; the forepart is the figure in the Plate which makes the third Piece, being a thin Plate of Iron of the same bigness as the Back of the Grate fix'd to the Box by the Bars *Tt, tT*, and another not seen in this Figure, but represented in the 4th. by *sT*.

C, P, Are two of the Feet, the other two being hid by the Plate *Dd yY*.

N. B. In *fig. 8.* *De* is 4 Foot 7 Inches long: *DF*, 23 Inches; *FG*, 8; *GH*, 6; and *He*, 18.

In *fig. 9.* *Ed*, is 18 Inches; *df*, 12; *fI*, 23.

Tho' there are but few Cavities in this Construction, and those but 36 Inches square; yet the Back of the Grate being almost always red hot, the External Air will acquire a greater degree of Heat, and pass with more Velocity, than in the Constructions for Wood-Fires; and this will make amends for the shortness and smallness of the Canals.

An Ash-Hole with a Grate over it must be made between *Z* and the Back, whose depth and description we dont give, because its use is so common in our Kitchens.

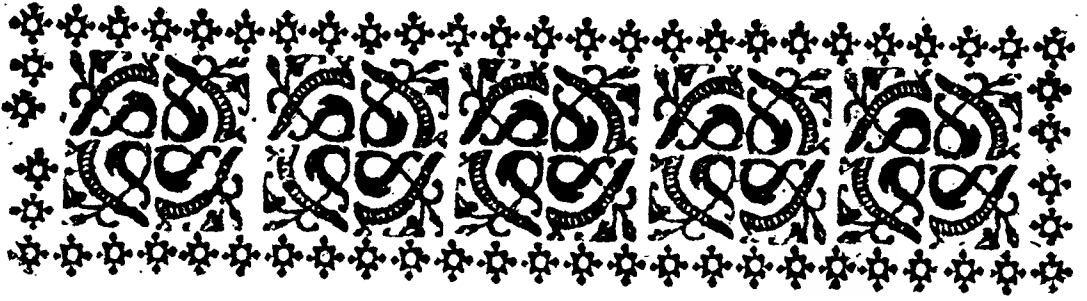

A

T A B L E

O F T H E

C O N T E N T S .

B O O K . I .

P A R T . I .

CHAP. I. **C**oncerning Fire, its Rays of Heat, and the way that we are warm'd by it. Page 7

CHAP. II. The common Way of Building Chimneys with the Jams parallel, and the Breast inclin'd is not proper for reflecting Heat into a Room. Page 10

CHAP. III.

The Contents.

CHAP. III. *Parabolical Jams, and an Horizontal Plane under the Chimney-Piece, are the fittest for reflecting Heat into a Room.*
Page 13

CHAP. IV. *Of the Vent-Hole or Bellows, the Reason of its blowing, and the manner of its encreasing the Heat, and causing it to be reflected.* Page 16

PART II.

BOOK I.

CHAP. I. **C**Concerning the sudden Heat given to the Air; and how the warmest Air gets above that which is Cold. Pag. 19

CHAP. II. *The inner Fabric of the inside of the Chimneys; how the Air goes into the Hollows, is warm'd, and then successively warms the whole Air of the Room; how the Air of another Room may be warm'd there, and other Advantages of this Contrivance.*
Page 23

CHAP. III. *After what manner the above-mention'd Cavities, may be made use of, for warming a Room, by letting in the External Air through them, tho' the Air be never so cold; the way that such Air goes into the Room, how it warms it, and the manner of knowing*

The Contents.

knowing in what time it will be sufficiently warm'd, how it may serve to increase or diminish the warmth, without encreasing or diminishing the Fire. Page 27

CHAP. IV. To shew that when a Room is warm'd by Air which is constantly new, it will defend us against several Inconveniencies, and especially the Ladies: That it is of great Advantage to Sick People, and those which visit them. Page 33

CHAP. V. External Air thus introduc'd, can be of no ill Consequence; but on the contrary, is very proper for Health. Page 35

CHAP. VI. That such as make use of Rooms warm'd after our Method, are less apt to catch Cold when they go out. Page 37

CHAP. VII. That a little while after the Fire is kindled, the External Air gives Heat to the Room, tho' it feels as if it were cold when it comes in, Page 39

PART III.

BOOK I.

CHAP. I. **H**OW the Hole of the Funnel at top of the House must be order'd, that the Heat of a Room may be encreas'd. Page 50

CHAP. II.

The Contents.

CHAP. II. *How to put out the Fire in the Fun-
nels of Chimneys in a Moment, and to re-
tain the Heat in a Room all Night long.*
Page 51

CHAP. III. *Of what use the Ash-Hole, and
the Instrument to cover the Fire is, in order
to preserve the Heat in the Night-time.* Pag. 53

B O O K II.

Concerning the Advantages of the New
Chimneys, in order to hinder the Smoke
from blowing into a Room; the Cause of
which, Builders seem not to have understood,
because hitherto they cou'd not wholly prevent
it. Pag. 55

P A R T I.

CHAP. I. **W**hat causes Rooms to Smoke,
with some Reflections con-
cerning Air. Page 55

CHAP. II. That parallel Jams or Sides, the
Inclination of the Breast or Part under the
Chimney-Piece, and the way that the Funnels
are carried, occasion Chimneys to smoke.
Page 61

CHAP. III.

The Contents.

CHAP. III. That Jams or Sides bent in a Parabolic form; the Horizontal Plane under the Chimney-Piece, and the Funnels carried in Curve Lines, when they are not carried directly up, are the most proper for hindering Smoke. Page 63

CHAP. IV. Concerning the Vent-Hole, and the way of laying the Wood in the best manner to prevent the Smoke. Page 67

P A R T II.

CHAP. I. **T**hat the External Air, which warms a Room by going thro' the Cavities behind the Back, does also hinder it from Smoking. Page 69

CHAP. II. Of the bigness of the opening of the Sides and Cavities of the Chimneys, in order to let in as much Air as is necessary to hinder the Smoke. Page 71

CHAP. III. That the coming in of the External Air to drive out the Smoke, does not hinder the Rays of Heat from coming into the Room. Page 73

P A R T III.

CHAP. I. **C**oncerning the truncated Pyramids, which may be added outwardly

The Contents.

outwardly to the Hole at top of the Funnel of Chimneys, to help the Smoke to go out, and hinder the Wind from coming in. Page 75

CHAP. II. Concerning the Capital to be added to the abovemention'd Pyramids, to hinder the Wind from blowing into such Chimneys as are commanded, or too much expos'd. Page 78

CHAP. III.

CHAP. IV. Shews how inconvenient the Smoke is, and how necessary it is to prevent it. Page 81

B O O K III.

P A R T I.

CHAP. I. **O**F the Model, by means of which, the Workman may give Chimneys that Sweep or Curvature which they ought to have. Page 85

CHAP. II. First Construction for the simple Chimneys. Page 88

CHAP. III. Second Construction, being that of Chimneys which supply us continually with new Air, which is warm'd in passing thro' Cavities behind the Back of the Chimneys. Pag. 90

The way of laying or fixing the second Construction for a Chimney. Page 92

CHAP. IV.

The Contents.

- CHAP. IV. *Third Construction, by which the fresh Air which comes constantly into the Room, is heated both behind the Back of the Chimney, and under the Hearth.* Page 97.
How to lay the third Construction for a Chimney. Page 101
- CHAP. V. *Fourth Construction, whereby the fresh Air coming continually into the Room, acquires Heat behind the Back, under the Hearth, and also under the Mantle-Tree or forepart of the Breast.* Page 102
How to lay the fourth Construction of a Chimney. Page 104
- CHAP. VI. *The fifth Construction, which is more simple than the foregoing, where the Air only passes behind the back of the Chimney, and is heated faster than in the other Constructions.* Page 105
How to lay the Box, for the fifth Construction of a Chimney. Page 109
- CHAP. VII. *Sixth Construction for such Chimneys as can have no Cavities behind the Back.* Page 113
- CHAP. VIII. *Seventh Construction for Chimneys in great Halls, or places to warm several People at once.* Page 115
- CHAP. IX. *How to make Air, which comes into the Room Temperate, in what degree of Heat or Cold you please.* Page 117.

CHAP. X.

The Contents.

CHAP. X. *Of the Vent-Hole or Bellows.*
Page 121.

PART II.

THis Part directs how to order the upper Part of the Funnel of the Chimneys, to hinder the Smoke, to increase the Heat, and to be able to put out the Fire in the Funnel.
Page 123

CHAP. I. *Of the first Construction apply'd outwardly to the top of the Funnel.* Page 124

CHAP. II. *Of the second Construction of the top of the Funnel of Chimneys.* Page 126

CHAP. III. *Of the Construction of the inside of the Funnel of Chimneys, in order to put out the Fire that might catch there, to keep in the Heat in a Room all Night long, and to hinder the Smoke of a Neighbouring Chimney from coming in; and also concerning the Instrument for covering the Fire.* Page 129

PART III.

OF the Effects and Advantages of the new Chimneys, and how to make use of them.
Page 134

P

CHAP. I.

The Contents.

*CHAP. I. Of the Effects and Properties of these
Chimneys. Page 134*

*CHAP. II. How to make use of the new Chim-
neys. Page 137*



Books

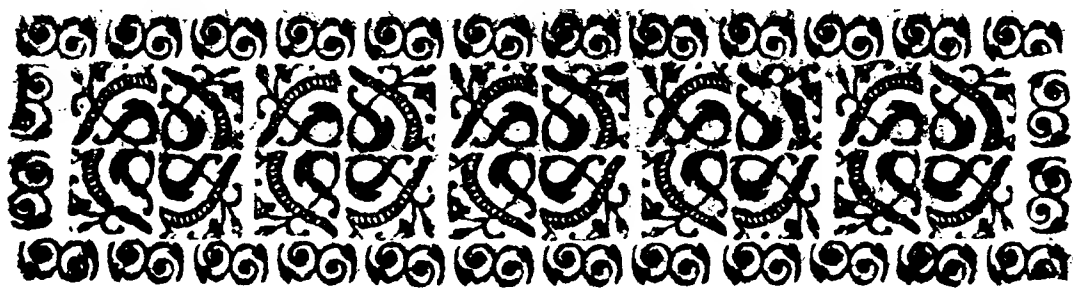

Books Printed for E. CURLL, at
the Dial and Bible against St. Dun-
stan's Church in Fleet-street.

I. **D**R. Gregory's Elements of *Catoptrics* and
Dioptrics. To which is added, 1. A
Method for finding the *Foci* of all *Specula*, as
well as *Lens*'s universally. As also for *Mag-
nifying* or *Lessening* a given Object by a given
Speculum or *Lens* in any assign'd Proportion,
&c. 2. A *Solution* of those *Problems* which
are left undemonstrated. 3. A particular
Account of *Microscopes* and *Telescopes*, from
Mr. *Huygens*. With an Introduction shew-
ing the Discoveries made by *Catoptrics* and
Dioptrics. By *W. Browne*, *A. M. & Med.*
Pract. Price 5 s.

II. The Lives and Characters of the most
Illustrious Persons, *British* and *Foreign*, who
died in the Years 1711, and 1712.

(*Viz.*)

British. The Dukes of *Rutland*, *Newcastle*,
Bedford, *Leeds*, *Hamilton*, &c. The Earls
of

Books Printed for, &c.

of *Bolingbroke, Rochester, Jersey, Ranelagh, Rivers, &c.* The Lords *Craven, Willoughby of Brooke, Mohun, &c.* *Anthony Henley, Arthur Manwaring, Esq; &c.*

Foreign. The Emperor *Joseph*, The Prince of *Friesland*, *Mareschal Boufflers*, The *Dauphine*, The Duke of *Vendome*, The *Mareschal De Catinat, &c.* The whole interspersed with many secret *Memoirs* concerning their respective Families, 2 Vol. Price 12 s.

III. The History and Antiquities of *St. Peter's Church at Westminster*; containing all the *Inscriptions, Epitaphs, &c.* upon the *Graves and Tomb-Stones*, with the *Lives, Marriages and Issue*, of the most eminent Personages therein deposited, and their *Coats of Arms truly Emblazoned*. Adorned with *Draughts of the Tombs curiously Engraven*. The second Edition. Price 7 s. 6 d.

F I N I S.

Plate II.

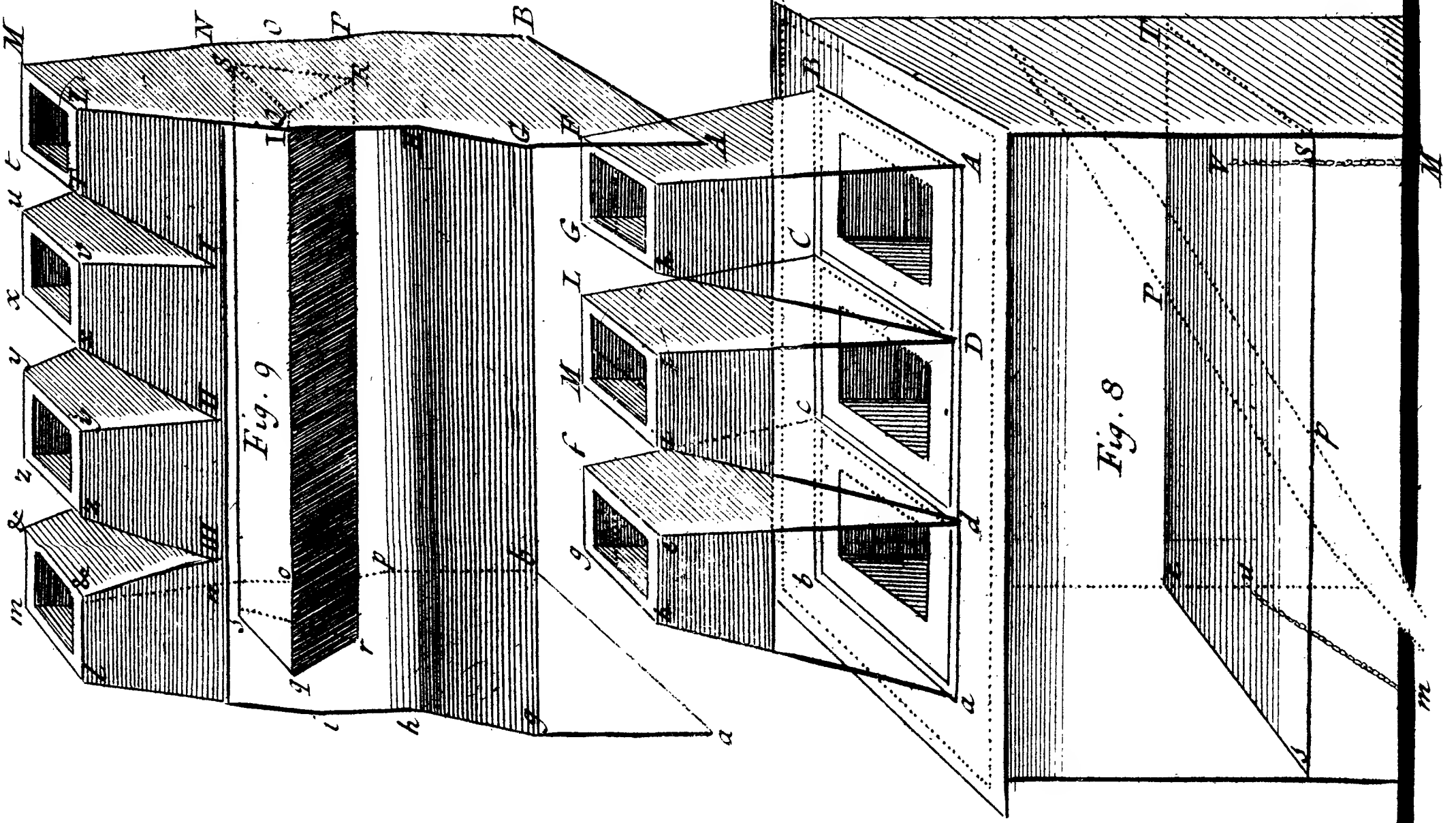
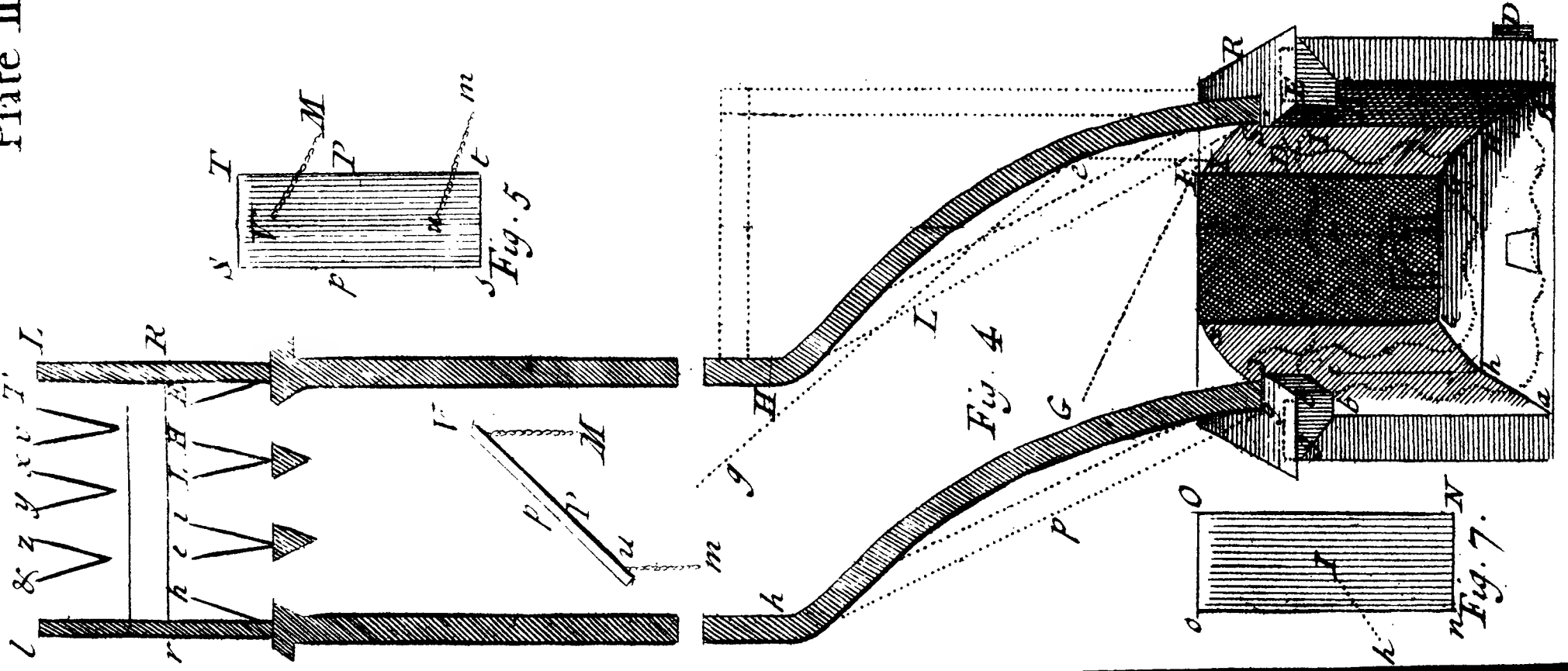
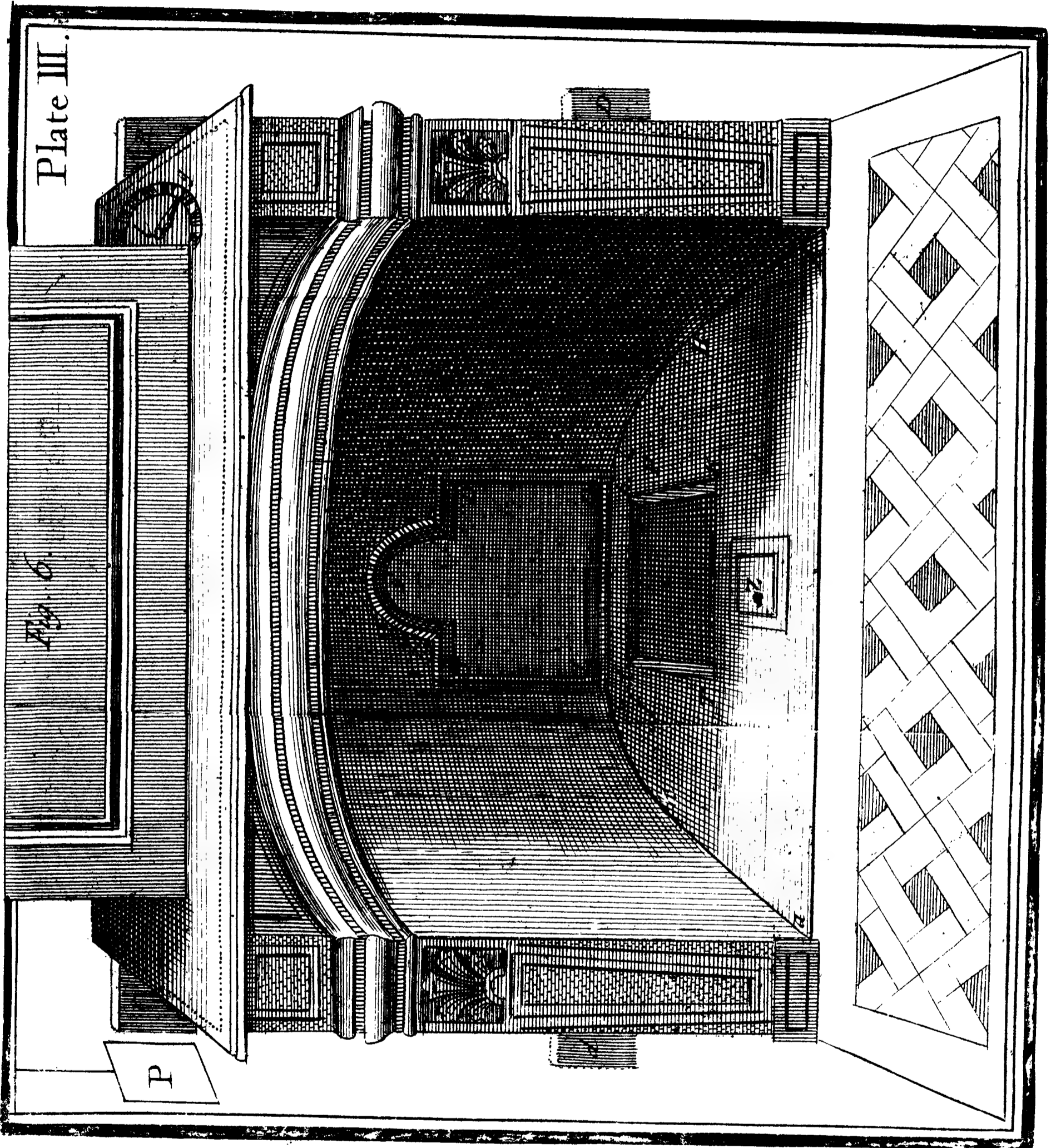

Plate III.



P

Plate IV.

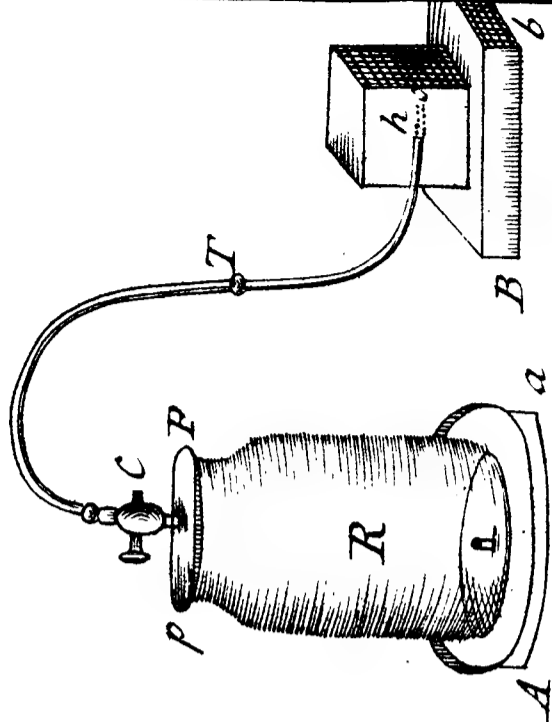
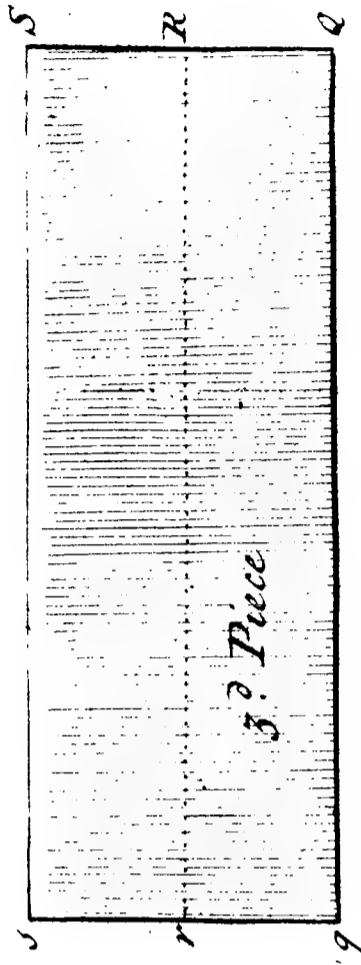
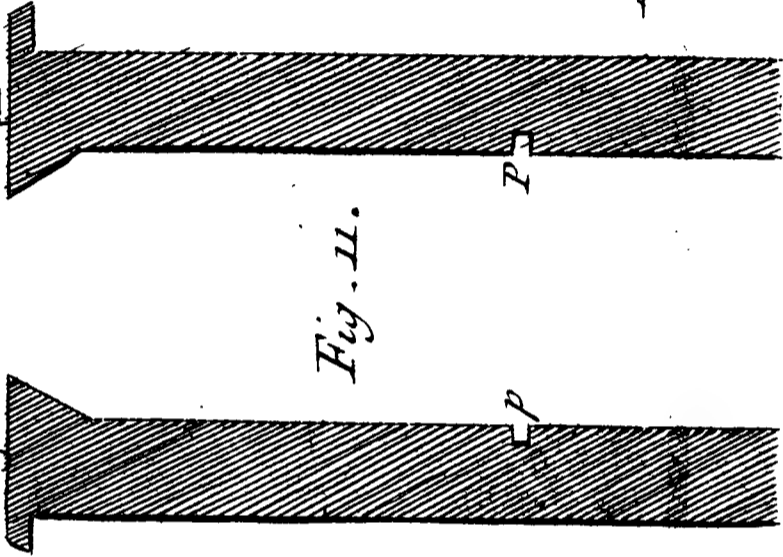
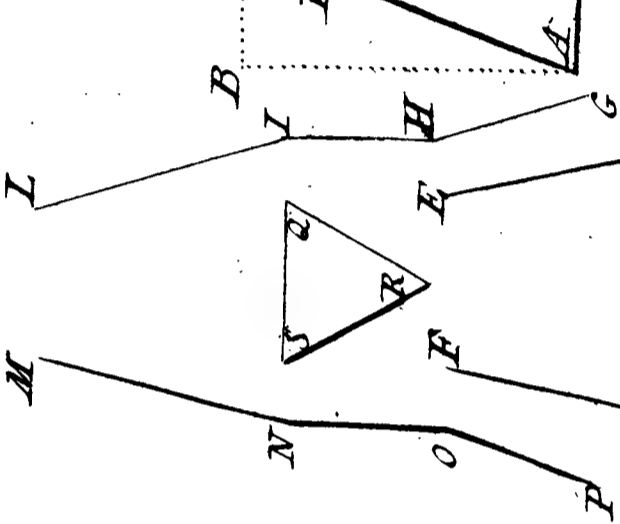
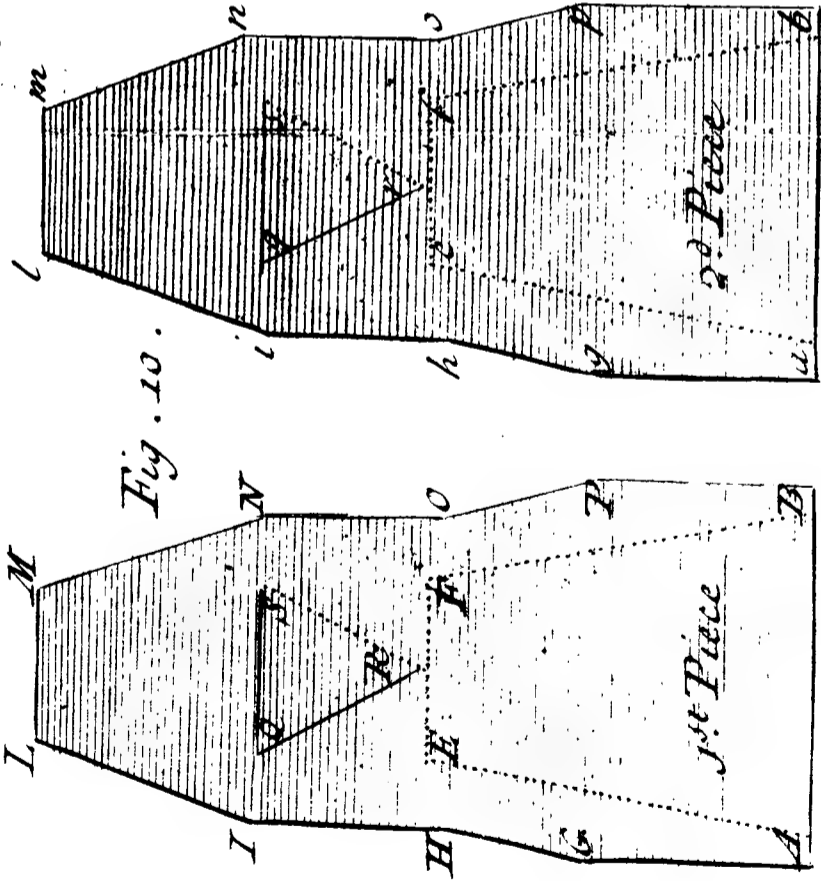
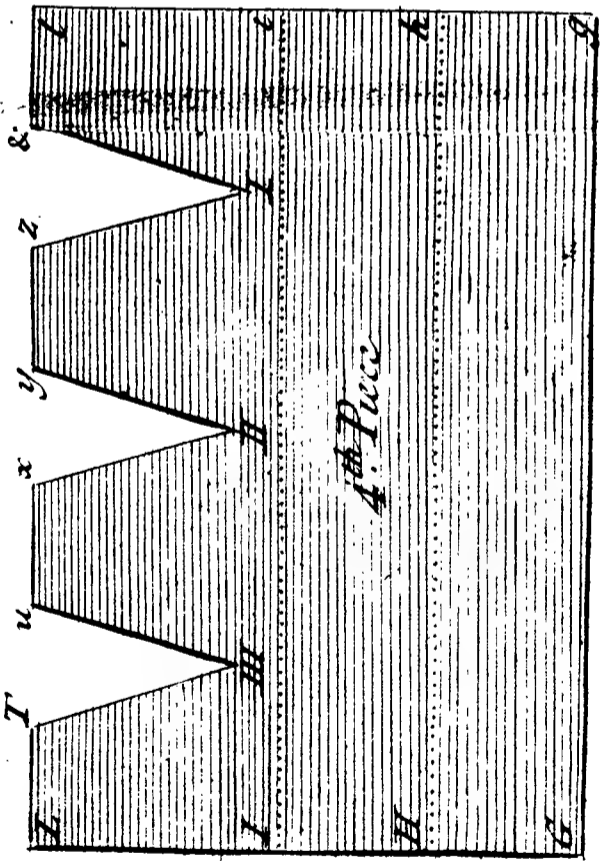
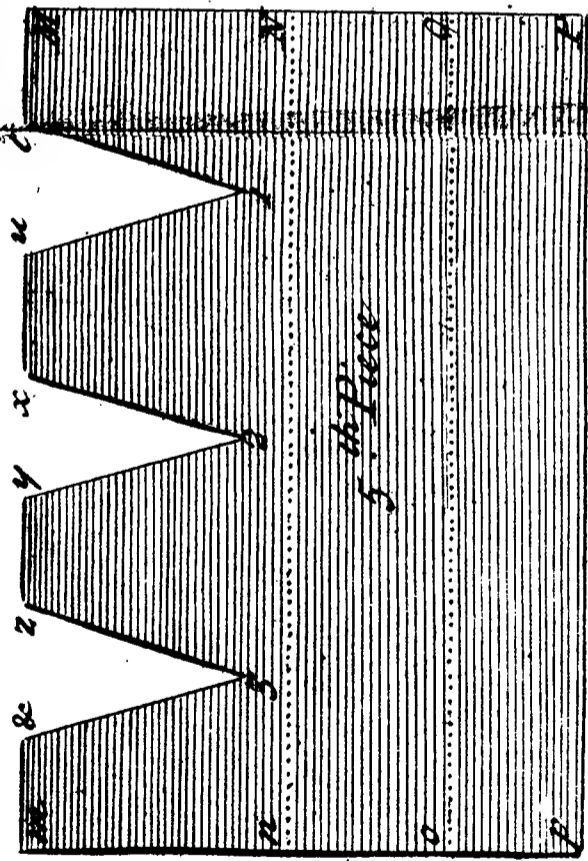

Fig. 11.

Fig. 10.

Fig. 12

Plate V

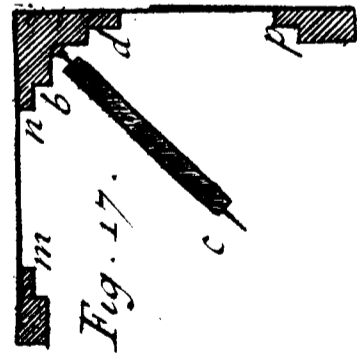
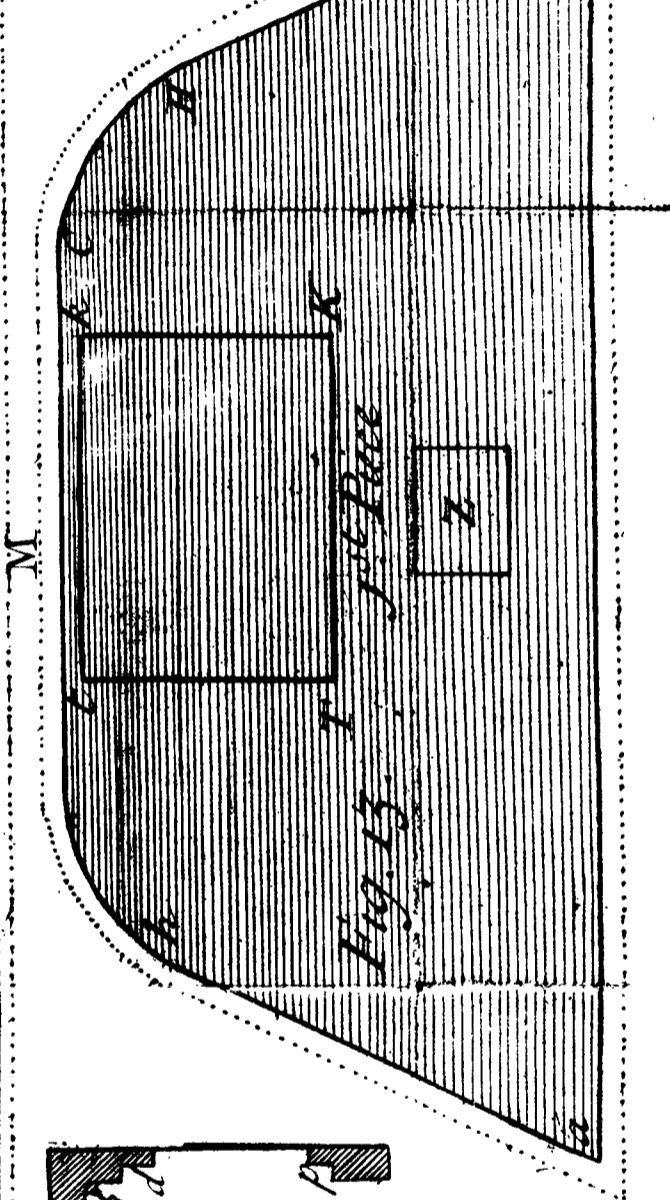
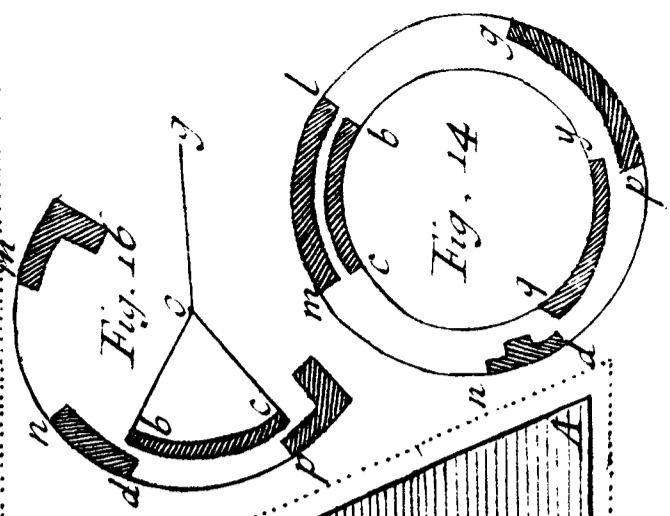
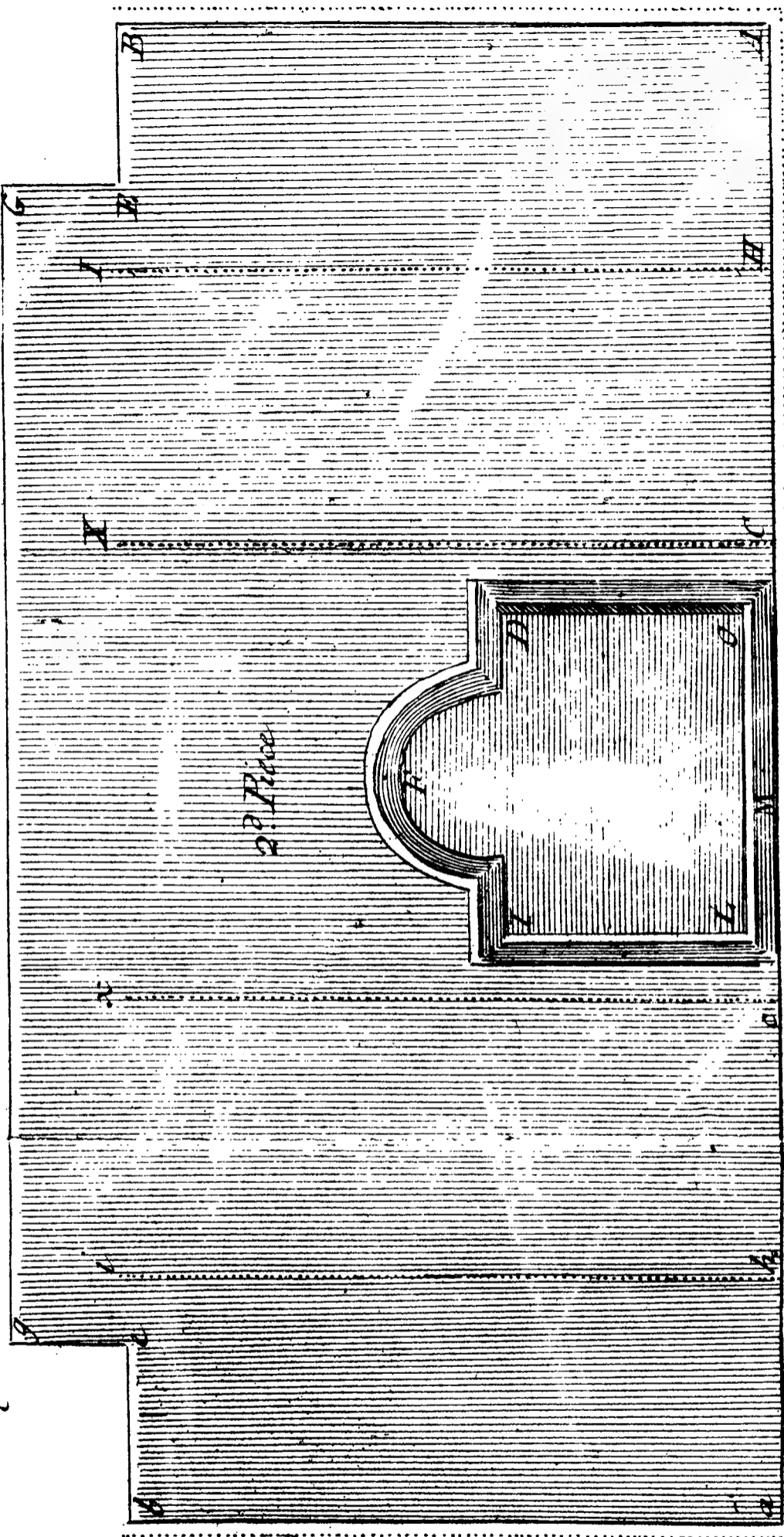
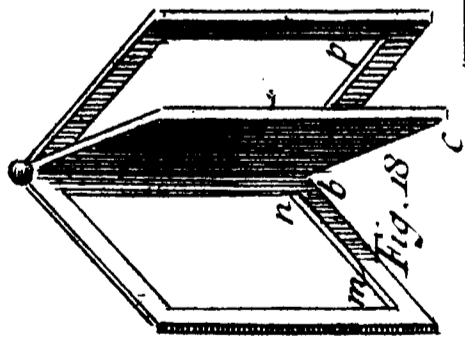
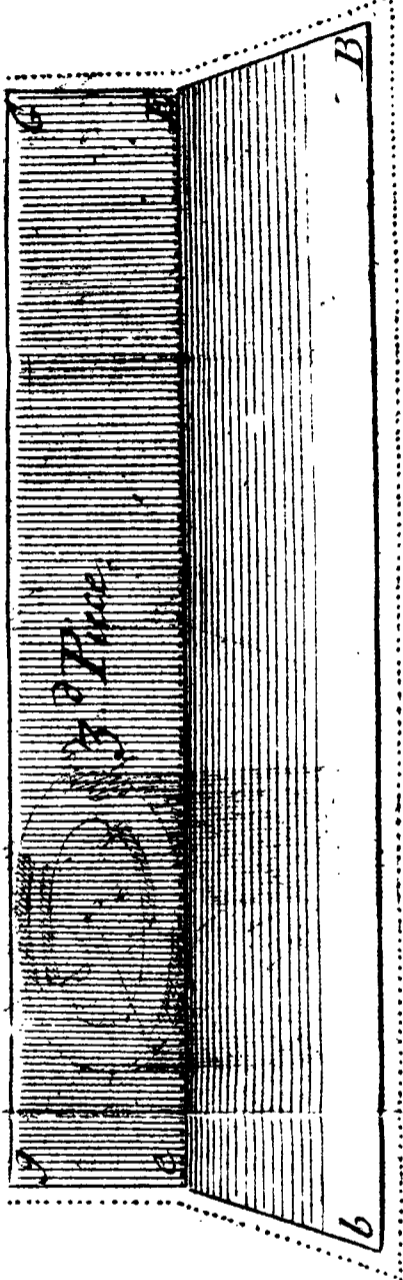
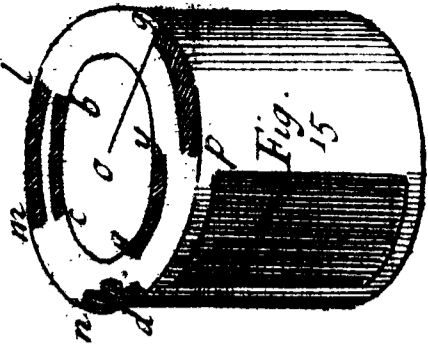

Plate VI.

Fig. 22.

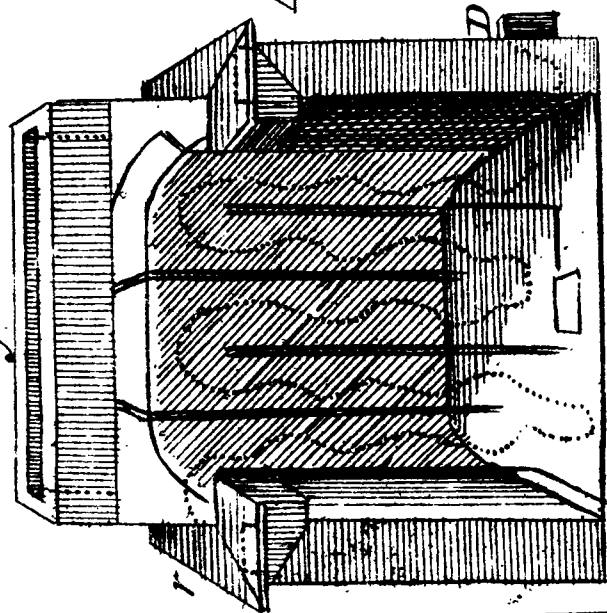

Fig. 23.

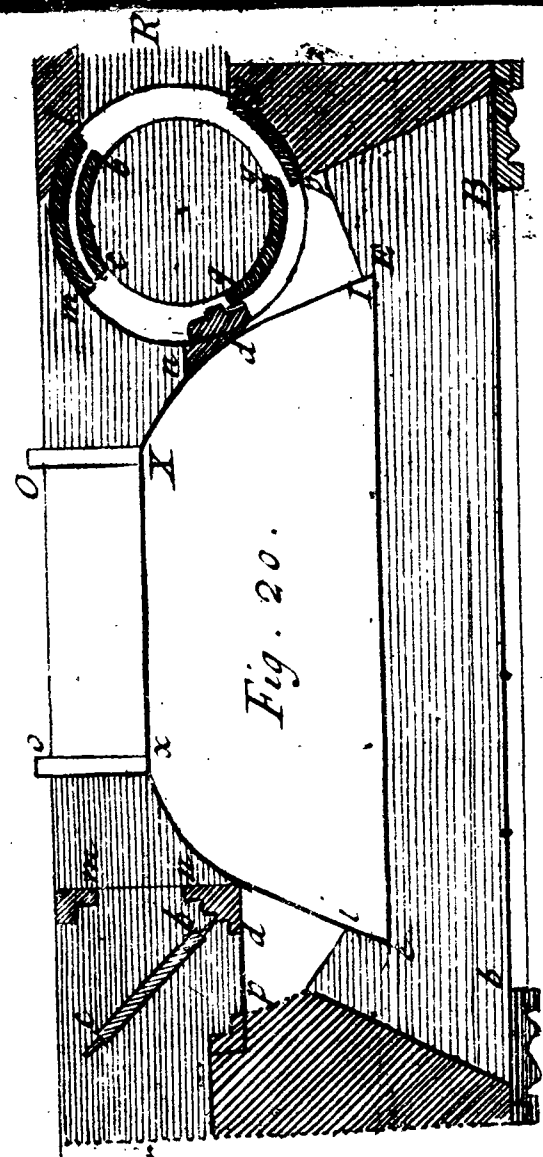
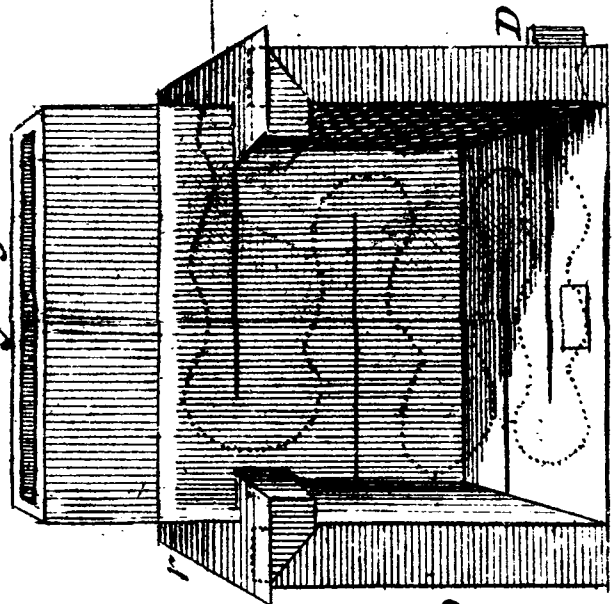

Fig. 20.

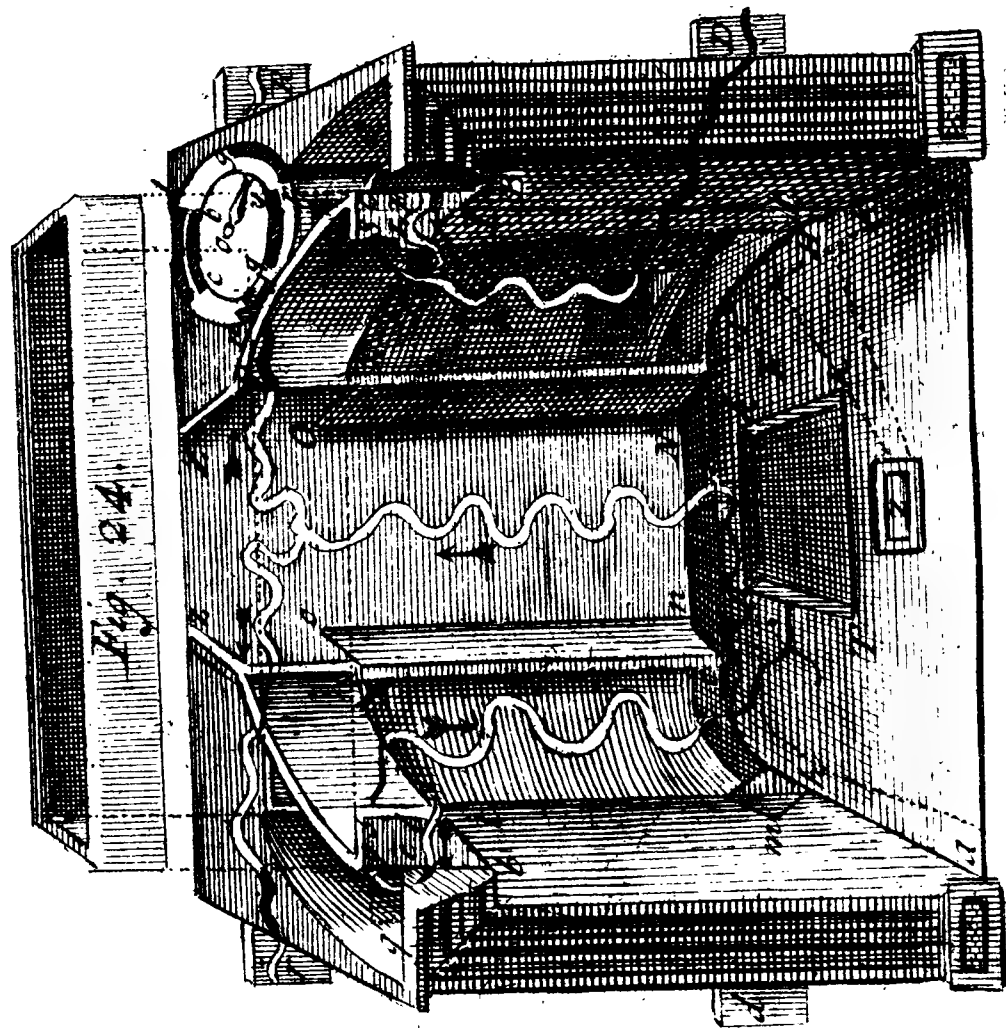

Fig. 24.

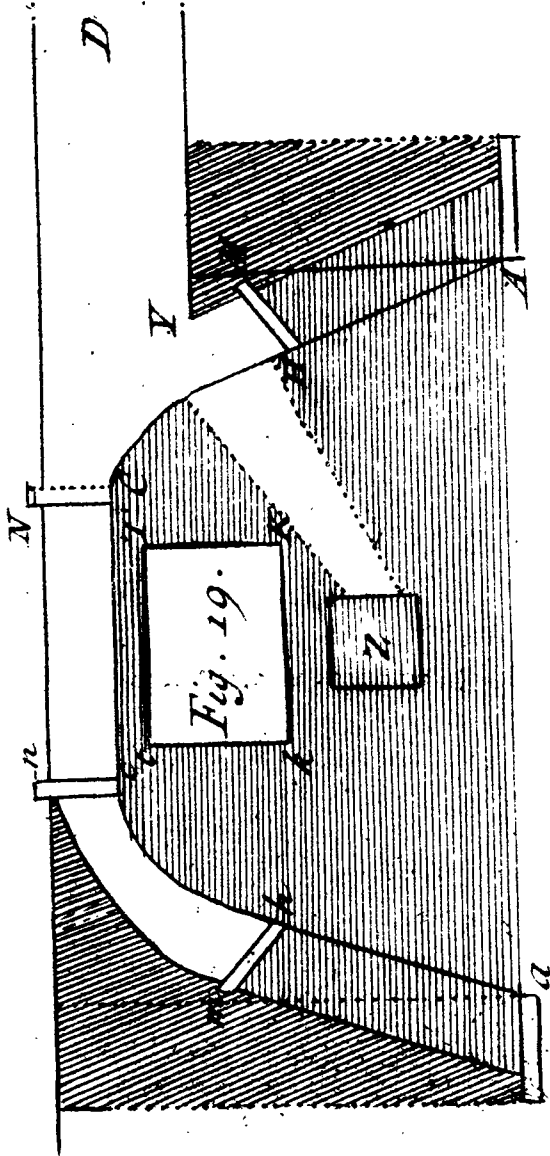

Fig. 19.

Plate VII.

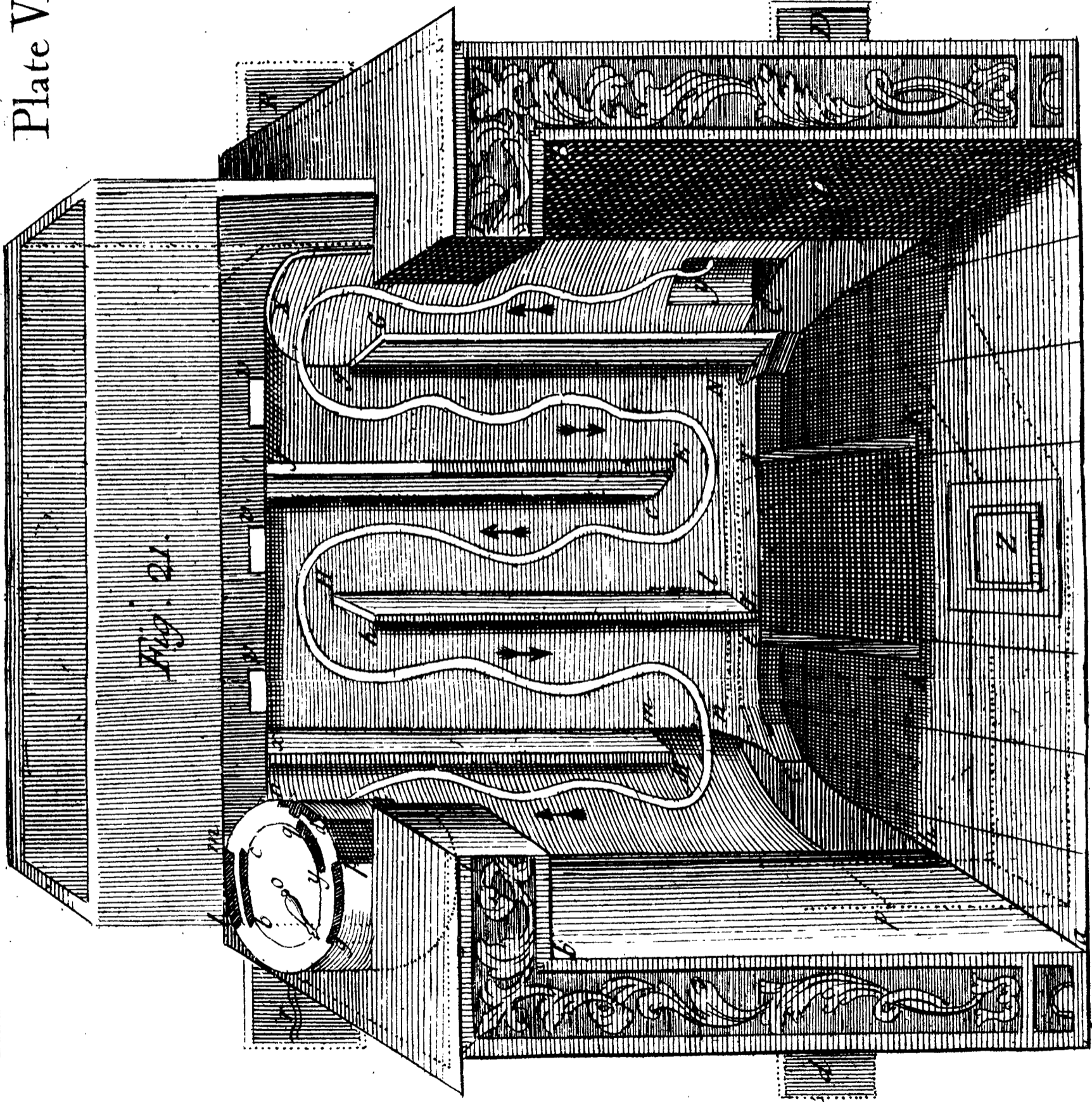

Fig. J.

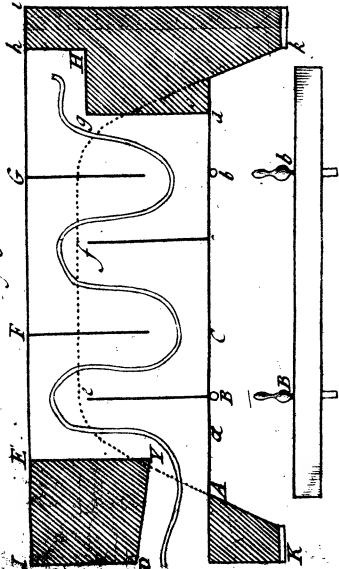

Fig. 2.

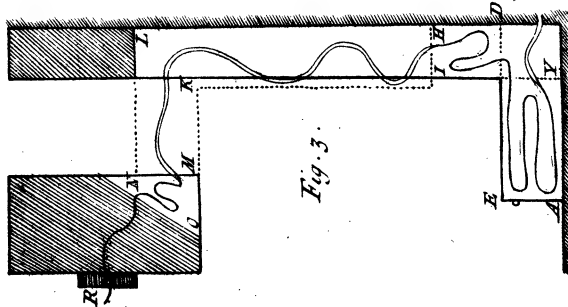
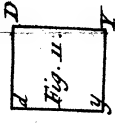
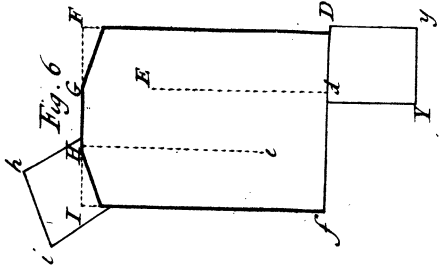
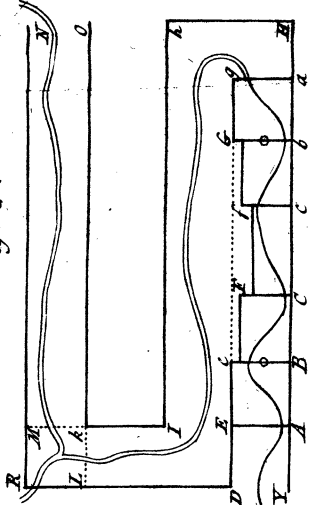

Fig. 3.

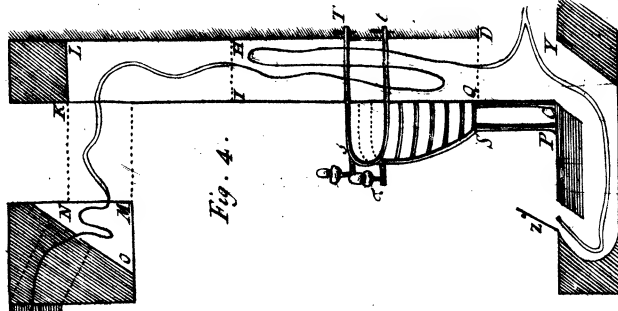

Fig. 4.

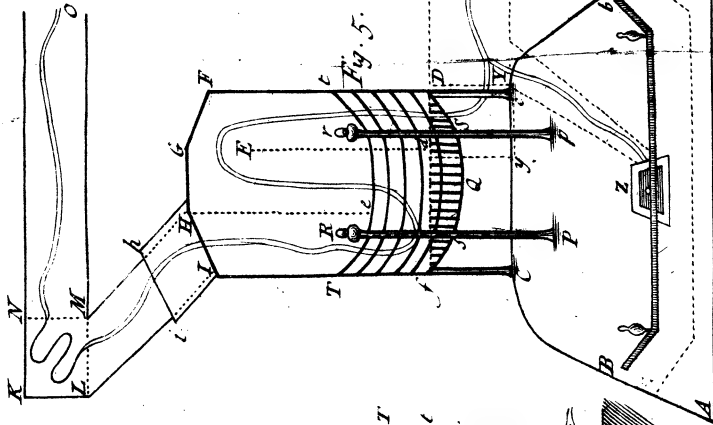

Fig. 5.

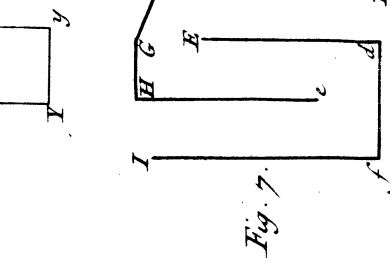

Fig. 7.

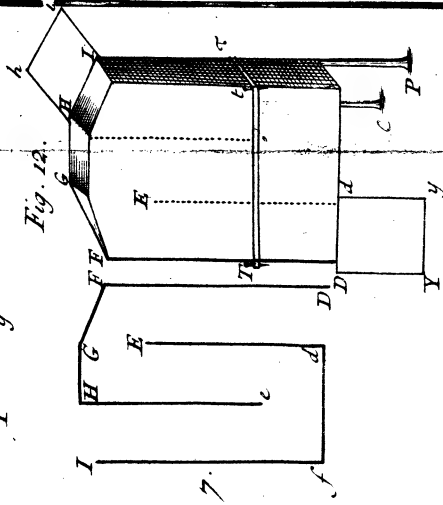

Fig. 12.

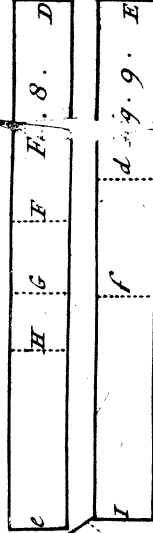

Fig. 8.

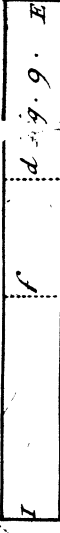

Fig. 9.

